

KHA/KHB SERIES

The KHA/KHB commercial heat pump is available in 7.5, 8.5, 10 and 12.5 ton capacities. The KHB commercial heat pump is available in 7.5, 8.5 and 10 ton capacities. The KHA092/150 and KHB 092/122 refrigerant systems utilize two compressors, two reversing valves, two accumulators, and other parts common to a heat pump. Optional auxiliary electric heat is factory or field installed in KHA/KHB units. Electric heat operates in single or multiple stages depending on the kW input size. 7.5kW through 60kW heat sections are available for the KHA/KHB heat pump.

KHA/KHB units are designed to accept any of several different energy management thermostat control systems with minimum field wiring.

Information contained in this manual is intended for use by qualified service technicians only. All specifications are subject to change. Procedures outlined in this manual are presented as a recommendation only and do not supersede or replace local or state codes.

If the unit must be lifted for service, rig unit by attaching four cables to the holes located in the unit base rail (two holes at each corner). Refer to the installation instructions for the proper rigging technique.



⚠ WARNING



Electric shock hazard. Can cause injury or death. Before attempting to perform any service or maintenance, turn the electrical power to unit OFF at disconnect switch(es). Unit may have multiple power supplies.

**ELECTROSTATIC DISCHARGE (ESD)
Precautions and Procedures**

⚠ CAUTION



Electrostatic discharge can affect electronic components. Take precautions to neutralize electrostatic charge by touching your hand and tools to metal prior to handling the control.

⚠ WARNING

Improper installation, adjustment, alteration, service or maintenance can cause property damage, personal injury or loss of life. Installation and service must be performed by a qualified installer or service agency.

⚠ CAUTION

As with any mechanical equipment, contact with sharp sheet metal edges can result in personal injury. Take care while handling this equipment and wear gloves and protective clothing.

Table of Contents

- Options / Accessories 2
- Optional Electric Heat Accessories 3
- Specifications 6
- Blower Data 8
- Electrical Data 13
- Parts Arrangement 21
- I Unit Components 22
 - Control Box 22
 - Cooling 31
 - Blower Compartment 30
 - Electric Heat 38
- II Placement and Installation 41
- III Start Up 41
- IV System Service Checks 42
- V Maintenance 43
- VI Accessories 45
- VII Wiring Diagrams 52

OPTIONS / ACCESSORIES

Item Description	Model Number	Catalog Number	Unit Model No				
			KHA	KHA	KHA	KHA	KHA
			KHB 092	KHB 102	KHB 120	KHB 122	KHB 150
COOLING SYSTEM							
Condensate Drain Trap	PVC - C1TRAP20AD2	76W26	X	X	X	X	X
	Copper - C1TRAP10AD2	76W27	X	X	X	X	X
Corrosion Protection		Factory	O	O	O	O	O
Drain Pan Overflow Switch	K1SNSR71AB1-	74W42	X	X	X	X	X
Efficiency		Standard	O	O	O		O
		High	O	O		O	
Low Ambient Kit	Standard Efficiency - K1SNSR33B-1	54W16	X	X	X		X
	High Efficiency - K1SNSR34*B0	14N31	X	X		X	
Refrigerant Type		R-410A	O	O	O	O	O
BLOWER - SUPPLY AIR							
Blower Option	CAV (Constant Air Volume)	Factory	O	O			O
	MSAV® (Multi-Stage Air Volume)	Factory	O	O	O		O
	DirectPlus™ (Direct Drive) MSAV® (Multi-Stage Air Volume)	Factory				O	
Blower Motors	Belt Drive - 2 hp	Factory	O	O	O		O
	Belt Drive - 3 hp	Factory	O	O	O		O
	Belt Drive - 5 hp	Factory	O	O	O		O
VFD Manual Bypass Kit (for MSAV equipped units only)	KVFDB12C-1	90W53	X	X	X		X
Drive Kits	Kit #1 590-890 rpm	Factory	O	O	O		O
See Blower Data Tables for selection	Kit #2 800-1105 rpm	Factory	O	O	O		O
	Kit #3 795-1195 rpm	Factory	O	O	O		O
	Kit #4 730-970 rpm	Factory	O	O	O		O
	Kit #5 940-1200 rpm	Factory	O	O	O		O
	Kit #6 1015-1300 rpm	Factory	O	O	O		O
	Kit #10 900-1135 rpm	Factory	O	O	O		O
	Kit #11 1040-1315 rpm	Factory	O	O	O		O
	Kit #12 1125-1425 rpm	Factory	O	O	O		O
	CABINET						
	Combination Coil/Hail Guards	Standard Efficiency - K1GARD51BS1	13T24	X	X	X	
Standard Efficiency - K1GARD51BP1		13T25					X
High Efficiency - K1GARD53B-1		14Y77	X	X			
High Efficiency - E1GARD51BP1		13T06				X	
Hinged Access Panels		Factory	O	O	O	O	O
Horizontal Discharge Kit	K1HECK00B-1	51W25	X	X	X	X	X
Return Air Adaptor Plate (for LC/LG/LH and TC/TG/TH unit replacement)	C1CONV10B-1	54W96	X	X	X	X	X
CONTROLS							
Commercial Controls	L Connection® Building Automation System	- - -	X	X	X	X	X
BACnet®	K0CTRL31B-1	96W15	OX	OX	OX	OX	OX
BACnet® Thermostat with Display	K0SNSR01FF1	97W23	X	X	X	X	X
BACnet® Thermostat without Display	K0SNSR00FF1	97W24	X	X	X	X	X
Novar® 2051	K0CTRL30B-1	96W12	OX	OX	OX	OX	OX
Plenum Cable (75 ft.)	K0MISC00FF1	97W25	X	X	X	X	X
Smoke Detector - Supply or Return (Power board and one sensor)	C1SNSR44B-2	11K76	X	X	X	X	X
Smoke Detector - Supply and Return (Power board and two sensors)	C1SNSR43B-2	11K80	X	X	X	X	X

NOTE - Catalog and model numbers shown are for ordering field installed accessories.

OX - Configure To Order (Factory Installed) or Field Installed

O = Configure To Order (Factory Installed)

X = Field Installed

OPTIONS / ACCESSORIES

Item Description	Model Number	Catalog Number	Unit Model No				
			KHA	KHA	KHA		KHA
			KHB 092	KHB 102	KHB 120	KHB 122	KHB 150
INDOOR AIR QUALITY							
Healthy Climate® High Efficiency Air Filters 20 x 25 x 2 (Order 4 per unit)	MERV 8 - C1FLTR15B-1	50W61	X	X	X	X	X
	MERV 13 - C1FLTR40B-1	52W41	X	X	X	X	X
Replacement Media Filter With Metal Mesh Frame (includes non-pleated filter media)	C1FLTR30B-1-	Y3063	X	X	X	X	X
Indoor Air Quality (CO₂) Sensors							
Sensor - Wall-mount, off-white plastic cover with LCD display	C0SNSR50AE1L	77N39	X	X	X	X	X
Sensor - Wall-mount, off-white plastic cover, no display	C0SNSR52AE1L	87N53	X	X	X	X	X
Sensor - Black plastic case with LCD display, rated for plenum mounting	C0SNSR51AE1L	87N52	X	X	X	X	X
Sensor - Wall-mount, black plastic case, no display, rated for plenum mounting	C0MISC19AE1	87N54	X	X	X	X	X
CO ₂ Sensor Duct Mounting Kit - for downflow applications	C0MISC19AE1-	85L43	X	X	X	X	X
Aspiration Box - for duct mounting non-plenum rated CO ₂ sensors (87N53 or 77N39)	C0MISC16AE1-	90N43	X	X	X	X	X
UVC Germicidal Lamps							
¹ Healthy Climate® UVC Light Kit (208/230v-1ph)	C1UVCL10B-1	54W62	X	X	X	X	X
ELECTRICAL							
Voltage 60 hz	208/230V - 3 phase	Factory	O	O	O	O	O
	460V - 3 phase	Factory	O	O	O	O	O
	575V - 3 phase	Factory	O	O	O	O	O
Disconnect Switch - See Electrical/Electric Heat tables for selection	80 amp - C1DISC080B-1	54W56	OX	OX	OX	OX	OX
	150 amp - C1DISC150B-1	54W57	OX	OX	OX	OX	OX
GFI Service Outlets	15 amp non-powered, field-wired (208/230V, 460V only) LTAGFIK10/15	74M70	OX	OX	OX	OX	OX
	20 amp non-powered, field-wired (575V only) C1GFIC120FF1	67E01	X	X	X	X	X
Weatherproof Cover for GFI	C1GFIC199FF1	10C89	X	X	X	X	X
ELECTRIC HEAT- BELT DRIVE UNITS							
7.5 kW	208/230V-3ph - C1EH0075B-1Y	56W38	OX	OX			
	460V-3ph - C1EH0075B-1G	56W39	OX	OX			
	575V-3ph - C1EH0075B-1J	56W40	OX	OX			
15 kW	208/230V-3ph - C1EH0015B-1Y	56W41	OX	OX	OX		OX
	460V-3ph - C1EH0150B-1G	56W42	OX	OX	OX		OX
	575V-3ph - C1EH0150B-1J	56W43	OX	OX	OX		OX
22.5 kW	208/230V-3ph - C1EH0225B-1Y	56W44	OX	OX	OX		OX
	460V-3ph - C1EH0225B-1G	56W45	OX	OX	OX		OX
	575V-3ph - C1EH0225B-1J	56W46	OX	OX	OX		OX
30 kW	208/230V-3ph - C1EH0300B-1Y	56W47	OX	OX	OX		OX
	460V-3ph - C1EH0300B-1G	56W48	OX	OX	OX		OX
	575V-3ph - C1EH0300B-1J	56W49	OX	OX	OX		OX
45 kW	208/230V-3ph - C1EH0450B-1Y	56W50	OX	OX	OX		OX
	460V-3ph - C1EH0450B-1G	56W51	OX	OX	OX		OX
	575V-3ph - C1EH0450B-1J	56W52	OX	OX	OX		OX
60 kW	208/230V-3ph - C1EH0600B-1Y	55W02			OX		OX
	460V-3ph - C1EH0600B-1G	55W03			OX		OX
	575V-3ph - C1EH0600B-1J	55W04			OX		OX

NOTE - Catalog and model numbers shown are for ordering field installed accessories.

OX - Configure To Order (Factory Installed) or Field Installed

O = Configure To Order (Factory Installed)

X = Field Installed

OPTIONS / ACCESSORIES

Item Description	Model Number	Catalog Number	Unit Model No				
			KHA KHB	KHA KHB	KHA KHB	KHA KHB	KHA KHB
			092	102	120	122	150
ELECTRIC HEAT- DIRECT DRIVE UNITS							
15 kW	208/230V-3ph - E1EH0150BP1Y	10U99				X	
	460V-3ph - E1EH0150BP1G	10X01				X	
	575V-3ph - E1EH0150BP1J	10X02				X	
22.5 kW	208/230V-3ph - E1EH0225BP1Y	10X03				X	
	460V-3ph - E1EH0225BP1G	10X04				X	
	575V-3ph - E1EH0225BP1J	10X05				X	
30 kW	208/230V-3ph - E1EH0300BP1Y	10X06				X	
	460V-3ph - E1EH0300BP1G	10X07				X	
	575V-3ph - E1EH0300BP1J	10X08				X	
45 kW	208/230V-3ph - E1EH0450BP1Y	10X09				X	
	460V-3ph - E1EH0450BP1G	10X11				X	
	575V-3ph - E1EH0450BP1J	10X12				X	
60 kW	208/230V-3ph - E1EH0600BP1Y	10X13				X	
	460V-3ph - E1EH0600BP1G	10X14				X	
	575V-3ph - E1EH0600BP1J	10X15				X	
ECONOMIZER							
Standard Economizer (Not for Title 24)							
Standard Economizer with Single Temperature Control Downflow or Horizontal Applications - Includes Barometric Relief Dampers and Air Hoods	K1ECON20B-2	13U45	OX	OX	OX	OX	OX
Standard Economizer Controls (Not for Title 24)							
Single Enthalpy Control	C1SNSR64FF1	53W64	OX	OX	OX	OX	OX
Differential Enthalpy Control (order 2)	C1SNSR64FF1	53W64	X	X	X	X	X
High Performance Economizer (Approved for California Title 24 Building Standards / AMCA Class 1A Certified)							
High Performance Economizer with Single Temperature Control Downflow or Horizontal Applications - Includes Barometric Relief Dampers and Air Hoods	K1ECON22B-1	10U58	OX	OX	OX	OX	OX
High Performance Economizer Controls (Not for Title 24)							
Single Enthalpy Control	C1SNSR60FF1	10Z75	OX	OX	OX	OX	OX
Differential Enthalpy Control (order 2)	C1SNSR60FF1	10Z75	X	X	X	X	X
Horizontal Low Profile Barometric Relief Dampers With Exhaust Hood							
Horizontal Low Profile Barometric Relief Dampers With Exhaust Hood	LAGEDH03/15	53K04	X	X	X	X	X
OUTDOOR AIR							
Outdoor Air Dampers with Outdoor Air Hood							
Motorized	C1DAMP20B-1	14G28	OX	OX	OX	OX	OX
Manual	C1DAMP10B-2	14G29	OX	OX	OX	OX	OX
POWER EXHAUST							
Standard Static	208/230V-3ph - K1PWRE10B-1Y	53W44	X	X	X	X	X
	460V-3ph - K1PWRE10B-1G	53W45	X	X	X	X	X
	575V-3ph - K1PWRE10B-1J	53W46	X	X	X	X	X

NOTE - Catalog and model numbers shown are for ordering field installed accessories.

OX - Configure To Order (Factory Installed) or Field Installed

O = Configure To Order (Factory Installed)

X = Field Installed

OPTIONS / ACCESSORIES

Item Description	Model Number	Catalog Number	Unit Model No				
			KHA	KHA	KHA		KHA
			KHB	KHB	KHB	KHB	KHB
			092	102	120	122	150
ROOF CURBS							
Hybrid Roof Curbs, Downflow							
8 in. height	C1CURB70B-1	11F54	X	X	X	X	X
14 in. height	C1CURB71B-1	11F55	X	X	X	X	X
18 in. height	C1CURB72B-1	11F56	X	X	X	X	X
24 in. height	C1CURB73B-1	11F57	X	X	X	X	X
Adjustable Pitch Curb, Downflow							
14 in. height	C1CURB55B-1	54W50	X	X	X	X	X
CEILING DIFFUSERS							
Step-Down - Order one	RTD11-95S	13K61	X				
	RTD11-135S	13K62		X	X	X	
	RTD11-185S	13K63					X
Flush - Order one	FD11-95S	13K56	X				
	FD11-135S	13K57		X	X	X	
	FD11-185S	13K58					X
Transitions (Supply and Return) - Order one	C1DIFF30B-1	12X65	X				
	C1DIFF31B-1	12X66		X	X	X	
	C1DIFF32B-1	12X67					X

NOTE - Catalog and model numbers shown are for ordering field installed accessories.

OX - Configure To Order (Factory Installed) or Field Installed

O = Configure To Order (Factory Installed)

X = Field Installed

SPECIFICATIONS - STANDARD EFFICIENCY

General Data		Nominal Tonnage	7.5 Ton	8.5 Ton	10 Ton	12.5 Ton
		Model Number	KHA092S4M	KHA102S4M	KHA120S4M	KHA150S4M
		Efficiency Type	Standard	Standard	Standard	Standard
		Blower Type	MSAV (Multi-Stage Air Volume)	MSAV (Multi-Stage Air Volume)	MSAV (Multi-Stage Air Volume)	MSAV (Multi-Stage Air Volume)
Cooling Performance	Gross Cooling Capacity - Btuh		91,600	103,400	121,500	144,300
	¹ Net Cooling Capacity - Btuh		89,000	100,000	118,000	138,000
	AHRI Rated Air Flow - cfm		3000	3400	3600	4500
	Total Unit Power - kW		8.1	9.1	10.7	13.0
	¹ EER (Btuh/Watt)		11	11	11.0	10.6
	¹ IEER (Btuh/Watt)		12.5	12.5	12.5	12.0
	Refrigerant Type		R-410A	R-410A	R-410A	R-410A
	Refrigerant Charge	Circuit 1	12 lbs. 8 oz.	13 lbs. 8 oz.	15 lbs. 0 oz.	22 lbs. 0 oz.
	Circuit 2	12 lbs. 0 oz.	13 lbs. 0 oz.	15 lbs. 0 oz.	23 lbs. 0 oz.	
Heating Performance	¹ Total High Heat Capacity - Btuh		89,000	100,000	115,000	138,000
	Total Unit Power - kW		7.9	8.9	10.3	12.6
	¹ C.O.P.		3.3	3.3	3.30	3.20
	¹ Total Low Heat Capacity - Btuh		53,000	55,000	70,000	82,000
	Total Unit Power (kW)		6.9	7.2	9.4	11.7
	¹ C.O.P.		2.25	2.25	2.25	2.05
Electric Heat Available - See page 14			7.5, 15, 22.5, 30 & 45 kW		15, 22.5, 30, 45 & 60 kW	
Compressor Type (number)			Scroll (2)		Scroll (2)	
Outdoor Coils	Net face area (total) - sq. ft.		28.8	28.8	28.8	40.8
	Tube diameter - in.		3/8	3/8	3/8	3/8
	Number of rows		2	2	3	3
	Fins per inch		20	20	20	20
Outdoor Coil Fans	Motor - (No.) horsepower		(2) 1/3 PSC	(2) 1/2 PSC	(2) 1/2 PSC	(3) 1/3 PSC
	Motor rpm		1075	1075	1075	1075
	Total Motor watts		665	775	806	1150
	Diameter - (No.) in.		(2) 24	(2) 24	(2) 24	(3) 24
	Number of blades		3	3	3	3
	Total Air volume - cfm		8200	8600	8800	11,000
Indoor Coils	Net face area (total) - sq. ft.		12.8	12.8	12.8	12.8
	Tube diameter - in.		3/8	3/8	3/8	3/8
	Number of rows		3	4	4	4
	Fins per inch		14	14	14	14
	Drain connection - Number and size		(1) 1 in. NPT coupling			
	Expansion device type	Balance port TXV, removable head				
² Indoor Blower and Drive Selection	Nominal motor output		2 hp, 3 hp, 5 hp			
	Maximum usable motor output (US Only)		2.3 hp, 3.45 hp, 5.75 hp			
	Motor - Drive kit number		2 hp ³ Kit 1 590-890 rpm Kit 2 800-1105 rpm Kit 3 795-1195 rpm 3 hp Kit 4 730-970 rpm Kit 5 940-1200 rpm Kit 6 1015-1300 rpm 5 hp Kit 10 900-1135 rpm Kit 11 1040-1315 rpm Kit 12 1125-1425 rpm			
	Blower wheel nominal diameter x width - in.		(1) 15 X 15	(1) 15 X 15	(1) 15 X 15	(1) 15 X 15
Filters	Type of filter		Disposable			
	Number and size - in.		(4) 20 x 25 x 2			
Electrical characteristics			208/230V, 460V or 575V - 60 hertz - 3 phase			

NOTE - Net capacity includes evaporator blower motor heat deduction. Gross capacity does not include evaporator blower motor heat deduction.

¹ AHRI Certified to AHRI Standard 340/360:

Cooling Ratings - 95°F outdoor air temperature and 80°F db/67°F wb entering indoor coil air.

High Temperature Heating Ratings - 47°F db/43°F wb outdoor air temperature and 70°F entering indoor coil air.

Low Temperature Heating Ratings - 17°F db/15°F wb outdoor air temperature and 70°F entering indoor coil air.

² Using total air volume and system static pressure requirements determine from blower performance tables rpm and motor output required. Maximum usable output of motors furnished are shown. In Canada, nominal motor output is also maximum usable motor output. If motors of comparable output are used, be sure to keep within the service factor limitations outlined on the motor nameplate.

⁴ Standard motor and drive kit furnished with unit.

NOTE - Units equipped with MSAV® (Multi-Stage Air Volume) option are limited to a motor service factor of 1.0.

SPECIFICATIONS - HIGH EFFICIENCY

General Data		Nominal Tonnage Model Number Efficiency Type	7.5 Ton KHB092H4B High	7.5 Ton KHB092H4M High	8.5 Ton KHB102H4B High	8.5 Ton KHB102H4M High	10 Ton KHB122H4E High
Blower Type			Constant Air Volume (CAV)	MSAV (Multi-Stage Air Volume)	Constant Air Volume (CAV)	MSAV (Multi-Stage Air Volume)	MSAV (Multi-Stage Air Volume) DirectPlus™ (Direct Drive)
Cooling Performance	Gross Cooling Capacity - Btuh		91,600	91,600	103,400	103,400	121,000
	¹ Net Cooling Capacity - Btuh		89,000	89,000	100,000	100,000	118,000
	AHRI Rated Air Flow - cfm		3,000	3,000	3,400	3,400	3600
	Total Unit Power - kW		7.3	7.3	8.3	8.3	9.6
	¹ EER (Btuh/Watt)		12.1	12.1	12.0	12.0	12.3
	¹ IEER (Btuh/Watt)		12.9	14.2	12.5	14.3	14.8
	Refrigerant Type		R-410A	R-410A	R-410A	R-410A	R-410A
Refrigerant Charge	Circuit 1		13 lbs. 8 oz.	13 lbs. 8 oz.	13 lbs. 8 oz.	13 lbs. 8 oz.	19 lbs. 8 oz.
	Furnished Circuit 2		13 lbs. 8 oz.	13 lbs. 8 oz.	13 lbs. 0 oz.	13 lbs. 0 oz.	20 lbs. 8 oz.
Heating Performance	¹ Total High Heat Capacity - Btuh		86,000	86,000	100,000	100,000	116,000
	Total Unit Power - kW		7.0	7.0	8.1	8.1	9.5
	¹ C.O.P.		3.60	3.60	3.60	3.60	3.60
	¹ Total Low Heat Capacity - Btuh		51,000	51,000	56,000	56,000	70,000
Total Unit Power (kW)			6.1	6.1	6.7	6.7	8.6
	¹ C.O.P.		2.40	2.40	2.40	2.40	2.40
Electric Heat Available - See page 14			7.5, 15, 22.5, 30 & 45 kW				15, 22.5, 30 & 45 kW
Compressor Type (number)			Scroll (2)	Scroll (2)	Scroll (2)	Scroll (2)	Scroll (2)
Outdoor Coils	Net face area (total) - sq. ft.		25.9	25.9	25.9	25.9	40.4
	Tube diameter - in.		3/8	3/8	3/8	3/8	3/8
	Number of rows		3	3	3	3	3
	Fins per inch		20	20	20	20	20
Outdoor Coil Fans	Motor - (No.) horsepower		(2) 1/3 ECM	(2) 1/3 ECM	(2) 1/3 ECM	(2) 1/3 ECM	(3) 1/3 ECM
	Motor rpm		530-950	530-950	650-1010	650-1010	530-950
	Total Motor watts		140-620	140-620	220-700	220-700	180-800
	Diameter - (No.) in.		(2) 24	(2) 24	(2) 24	(2) 24	(3) 24
	Number of blades		3	3	3	3	3
	Total Air volume - cfm		3600-7000	3600-7000	4600-7500	4600-7500	5500-10,600
Indoor Coils	Net face area (total) - sq. ft.		12.8	12.8	12.8	12.8	12.8
	Tube diameter - in.		3/8	3/8	3/8	3/8	3/8
	Number of rows		4	4	4	4	4
	Fins per inch		14	14	14	14	14
	Drain connection - Number and size		(1) 1 in. NPT coupling				
Expansion device type			Balance port TXV, removable head				
² Indoor Blower and Drive Selection	Nominal motor output		2 hp, 3 hp, 5 hp				3.75 hp (ECM)
	Maximum usable motor output (US Only)		2.3 hp, 3.45 hp, 5.75 hp				- - -
	Motor - Drive kit number		2 hp ³ Kit 1 590-890 rpm Kit 2 800-1105 rpm Kit 3 795-1195 rpm		3 hp Kit 4 730-970 rpm Kit 5 940-1200 rpm Kit 6 1015-1300 rpm		- - -
Blower wheel nominal diameter x width - in.			(1) 15 X 15	(1) 15 X 15	(1) 15 X 15	(1) 15 X 15	(1) 22 x 19
Filters	Type of filter		Disposable				
	Number and size - in.		(4) 20 x 25 x 2				
Electrical characteristics			208/230V, 460V or 575V - 60 hertz - 3 phase				

NOTE - Net capacity includes evaporator blower motor heat deduction. Gross capacity does not include evaporator blower motor heat deduction.

¹ AHRI Certified to AHRI Standard 340/360:

Cooling Ratings - 95°F outdoor air temperature and 80°F db/67°F wb entering indoor coil air.

High Temperature Heating Ratings - 47°F db/43°F wb outdoor air temperature and 70°F entering indoor coil air.

Low Temperature Heating Ratings - 17°F db/15°F wb outdoor air temperature and 70°F entering indoor coil air.

² Using total air volume and system static pressure requirements determine from blower performance tables rpm and motor output required. Maximum usable output of motors furnished are shown. In Canada, nominal motor output is also maximum usable motor output. If motors of comparable output are used, be sure to keep within the service factor limitations outlined on the motor nameplate.

⁴ Standard motor and drive kit furnished with unit.

NOTE - Units equipped with MSAV® (Multi-Stage Air Volume) option are limited to a motor service factor of 1.0.

KHA092S4M - BASE UNIT

BLOWER TABLE INCLUDES RESISTANCE FOR BASE UNIT ONLY (NO HEAT SECTION) WITH DRY INDOOR COIL AND AIR FILTERS IN PLACE. FOR ALL UNITS ADD:

- 1 – Wet indoor coil air resistance of selected unit.
- 2 – Any factory installed options air resistance (heat section, economizer, etc.)
- 3 – Any field installed accessories air resistance (duct resistance, diffuser, etc.)

Then determine from blower table blower motor output required.

See page 11 for blower motors and drives.

See page 11 for wet coil and option/accessory air resistance data.

MINIMUM AIR VOLUME REQUIRED FOR USE WITH OPTIONAL ELECTRIC HEAT (Maximum Static Pressure - 2.0 in. w.g.)

7.5 kW, 15 kW, 22.5 kW, 30 kW and 45 kW - 2800 cfm

Total Air Volume cfm	Total Static Pressure – in. w.g.													
	0.2		0.4		0.6		0.8		1.0		1.2		1.4	
	RPM	BHP	RPM	BHP	RPM	BHP	RPM	BHP	RPM	BHP	RPM	BHP	RPM	BHP
1750	583	0.09	627	0.06	673	0.09	723	0.06	777	0.45	834	0.82	892	1.13
2000	593	0.11	636	0.07	682	0.10	731	0.22	784	0.60	840	0.96	898	1.26
2250	604	0.15	645	0.11	690	0.15	739	0.39	790	0.74	846	1.08	901	1.34
2500	615	0.19	655	0.15	699	0.20	747	0.55	797	0.89	851	1.20	906	1.44
2750	626	0.23	666	0.19	709	0.37	755	0.71	805	1.03	858	1.32	912	1.55
3000	637	0.27	677	0.24	719	0.55	764	0.87	813	1.18	866	1.45	920	1.67
3250	650	0.31	688	0.43	730	0.73	775	1.04	823	1.34	875	1.60	930	1.81
3500	663	0.35	700	0.63	741	0.92	786	1.22	834	1.50	886	1.76	942	1.96
3750	676	0.57	714	0.84	754	1.12	798	1.41	846	1.68	899	1.93	956	2.14

Total Air Volume cfm	Total Static Pressure – in. w.g.											
	1.6		1.8		2		2.2		2.4		2.6	
	RPM	BHP	RPM	BHP	RPM	BHP	RPM	BHP	RPM	BHP	RPM	BHP
1750	943	1.28	990	1.38	1038	1.44	1084	1.60	1131	1.79	1179	2.25
2000	948	1.38	996	1.47	1045	1.57	1092	1.71	1140	1.92	1188	2.32
2250	953	1.48	1002	1.57	1052	1.70	1100	1.86	1149	2.09	1197	2.42
2500	959	1.58	1009	1.68	1059	1.83	1108	2.01	1158	2.26	1206	2.52
2750	966	1.70	1017	1.81	1067	1.97	1117	2.17	1166	2.44	1215	2.71
3000	975	1.82	1026	1.96	1076	2.13	1126	2.35	1176	2.63	1225	2.92
3250	985	1.97	1036	2.12	1086	2.31	1136	2.54	1186	2.83	1235	3.13
3500	997	2.14	1048	2.31	1097	2.51	1147	2.75	1196	3.04	1245	3.35
3750	1010	2.32	1060	2.51	1109	2.72	1158	2.98	1207	3.27	1255	3.58

BLOWER DATA - BELT DRIVE - STANDARD / HIGH EFFICIENCY

7.5, 8.5, 10, 12.5 TON

KHA102S4M, KHA120S4M, KHA150S4M AND KHB092H4B/M, KHB102H4B/M - BASE UNIT

BLOWER TABLE INCLUDES RESISTANCE FOR BASE UNIT ONLY (NO HEAT SECTION) WITH DRY INDOOR COIL AND AIR FILTERS IN PLACE. FOR ALL UNITS ADD:

- 1 - Wet indoor coil air resistance of selected unit.
 - 2 - Any factory installed options air resistance (heat section, economizer, etc.)
 - 3 - Any field installed accessories air resistance (duct resistance, diffuser, etc.)
- Then determine from blower table blower motor output required.

See page 11 for blower motors and drives.

See page 11 for wet coil and option/accessory air resistance data.

MINIMUM AIR VOLUME REQUIRED FOR USE WITH OPTIONAL ELECTRIC HEAT (Maximum Static Pressure - 2.0 in. w.g.)

7.5 kW, 15 kW, 22.5 kW, 30 kW and 45 kW - 2800 cfm

60 kW - 4000 cfm

Total Air Volume cfm	Total Static Pressure - in. w.g.													
	0.2		0.4		0.6		0.8		1.0		1.2		1.4	
	RPM	BHP	RPM	BHP	RPM	BHP	RPM	BHP	RPM	BHP	RPM	BHP	RPM	BHP
1750	480	0.19	548	0.39	618	0.57	689	0.70	758	0.81	824	0.92	885	1.07
2000	492	0.27	560	0.47	629	0.64	700	0.77	768	0.88	832	1.00	892	1.16
2250	505	0.35	573	0.55	643	0.72	713	0.85	780	0.97	842	1.10	900	1.25
2500	520	0.45	588	0.64	658	0.81	727	0.94	793	1.07	853	1.21	909	1.37
2750	536	0.55	604	0.74	674	0.91	743	1.05	806	1.19	865	1.34	919	1.50
3000	553	0.66	622	0.85	692	1.02	760	1.17	821	1.32	878	1.48	930	1.64
3250	572	0.77	641	0.98	712	1.15	778	1.32	837	1.48	892	1.64	942	1.81
3500	592	0.90	663	1.12	733	1.31	798	1.48	854	1.65	907	1.82	955	1.99
3750	614	1.04	687	1.28	756	1.48	818	1.66	872	1.83	922	2.01	969	2.19
4000	639	1.22	712	1.47	780	1.67	838	1.85	890	2.03	939	2.22	983	2.42
4250	666	1.42	740	1.68	804	1.88	859	2.06	909	2.25	956	2.45	998	2.67
4500	697	1.65	769	1.91	829	2.10	881	2.28	929	2.48	973	2.71	1013	2.95
4750	729	1.91	798	2.15	854	2.34	903	2.53	948	2.75	991	3.00	1030	3.27
5000	763	2.18	826	2.41	878	2.60	925	2.81	968	3.05	1009	3.33	1046	3.61
5250	797	2.47	854	2.69	903	2.90	947	3.12	989	3.39	1028	3.69	1064	3.99
5500	830	2.78	882	3.00	927	3.22	969	3.48	1010	3.77	1047	4.09	1083	4.40
5750	861	3.11	908	3.34	951	3.58	992	3.87	1031	4.19	1068	4.52	1102	4.84
6000	890	3.45	935	3.71	976	3.98	1016	4.31	1053	4.65	1089	4.99	1122	5.30
6250	918	3.84	961	4.12	1001	4.43	1040	4.79	1076	5.14	1110	5.48	---	---

Total Air Volume cfm	Total Static Pressure - in. w.g.											
	1.6		1.8		2		2.2		2.4		2.6	
	RPM	BHP	RPM	BHP	RPM	BHP	RPM	BHP	RPM	BHP	RPM	BHP
1750	941	1.23	992	1.40	1039	1.55	1084	1.70	1128	1.85	1156	2.08
2000	946	1.32	995	1.48	1041	1.65	1085	1.81	1127	1.97	1160	2.13
2250	952	1.42	999	1.59	1044	1.76	1087	1.93	1127	2.10	1164	2.27
2500	959	1.54	1005	1.71	1048	1.89	1089	2.07	1127	2.25	1166	2.42
2750	968	1.67	1012	1.86	1053	2.04	1092	2.23	1129	2.41	1167	2.60
3000	977	1.83	1020	2.02	1059	2.21	1096	2.41	1133	2.60	1170	2.79
3250	988	2.00	1028	2.20	1066	2.41	1102	2.61	1138	2.81	1174	3.01
3500	999	2.19	1038	2.41	1074	2.63	1109	2.84	1144	3.04	1180	3.24
3750	1010	2.41	1048	2.64	1084	2.87	1118	3.09	1152	3.29	1188	3.50
4000	1023	2.65	1060	2.90	1095	3.14	1128	3.36	1162	3.57	1198	3.77
4250	1036	2.92	1072	3.18	1106	3.42	1139	3.65	1172	3.86	1208	4.07
4500	1050	3.22	1085	3.48	1118	3.73	1151	3.96	1184	4.17	1221	4.39
4750	1065	3.55	1099	3.81	1132	4.06	1164	4.29	1198	4.51	1235	4.74
5000	1081	3.90	1114	4.17	1146	4.42	1178	4.65	1212	4.87	1250	5.09
5250	1098	4.28	1130	4.55	1162	4.80	1194	5.02	1228	5.24	1266	5.47
5500	1116	4.69	1147	4.96	1179	5.20	1211	5.42	1246	5.63	---	---
5750	1134	5.12	1165	5.38	1196	5.61	---	---	---	---	---	---
6000	1153	5.58	---	---	---	---	---	---	---	---	---	---
6250	---	---	---	---	---	---	---	---	---	---	---	---

KHB122H4E - BASE UNIT

BLOWER TABLE INCLUDES RESISTANCE FOR BASE UNIT ONLY (NO HEAT SECTION) WITH DRY INDOOR COIL AND AIR FILTERS IN PLACE. FOR ALL UNITS ADD:

- 1 - Wet indoor coil air resistance of selected unit.
- 2 - Any factory installed options air resistance (heat section, economizer, etc.)
- 3 - Any field installed accessories air resistance (duct resistance, diffuser, etc.)

See page 11 for wet coil and option/accessory air resistance data.

MINIMUM AIR VOLUME REQUIRED FOR USE WITH OPTIONAL ELECTRIC HEAT (Maximum Static Pressure - 2.0 in. w.g.)

15 kW, 22.5 kW, 30 kW, 45 kW - 2750 cfm

60 kW - 3500 cfm

Total Air Volume cfm	Total Static Pressure - in. w.g.													
	0.2		0.4		0.6		0.8		1.0		1.2		1.4	
	RPM	Watts	RPM	Watts	RPM	Watts	RPM	Watts	RPM	Watts	RPM	Watts	RPM	Watts
1750	711	188	771	279	836	366	905	453	975	544	1044	640	1109	737
2000	752	242	812	332	876	420	944	510	1011	606	1075	709	1138	812
2250	799	300	860	389	923	479	988	575	1052	678	1113	787	1171	896
2500	853	362	914	453	976	548	1038	650	1097	761	1154	877	1209	990
2750	914	434	974	529	1033	629	1091	739	1146	858	1199	979	1250	1098
3000	980	513	1037	614	1092	720	1146	837	1198	961	1247	1088	1295	1215
3250	1048	598	1101	705	1153	819	1203	941	1251	1071	1298	1206	1343	1343
3500	1116	693	1166	809	1214	931	1261	1060	1307	1198	1351	1341	1395	1489
3750	1185	806	1232	931	1277	1063	1322	1201	1365	1348	1407	1499	1448	1657
4000	1254	937	1299	1072	1341	1214	1383	1363	1424	1518	1464	1679	1503	1844
4250	1324	1089	1366	1234	1406	1386	1445	1545	1484	1708	1522	1876	1559	2046
4500	1395	1262	1433	1417	1471	1579	1508	1745	1544	1913	1581	2084	1616	2256
4750	1465	1455	1501	1619	1536	1787	1571	1957	1606	2128	1641	2299	1675	2470
5000	1534	1666	1568	1834	1602	2004	1635	2174	1668	2345	1701	2514	1735	2682
5250	1603	1887	1635	2055	1667	2224	1699	2392	1731	2559	1763	2724	---	---
5500	1671	2110	1702	2275	1733	2441	1764	2605	---	---	---	---	---	---
5750	1738	2325	1768	2488	---	---	---	---	---	---	---	---	---	---

Total Air Volume cfm	Total Static Pressure - in. w.g.											
	1.6		1.8		2.0		2.2		2.4		2.6	
	RPM	Watts	RPM	Watts	RPM	Watts	RPM	Watts	RPM	Watts	RPM	Watts
1750	1172	833	1231	932	1287	1039	1340	1156	1391	1283	1442	1426
2000	1197	913	1253	1019	1306	1135	1357	1261	1407	1398	1457	1547
2250	1227	1003	1280	1117	1330	1242	1379	1378	1428	1525	1477	1680
2500	1261	1103	1311	1226	1360	1361	1407	1507	1454	1663	1501	1826
2750	1299	1219	1347	1350	1394	1494	1440	1649	1485	1813	1530	1982
3000	1342	1346	1388	1487	1432	1640	1476	1803	1520	1973	1563	2146
3250	1388	1485	1432	1638	1475	1800	1517	1969	1558	2143	1600	2319
3500	1437	1643	1479	1805	1519	1975	1560	2148	1600	2325	1640	2502
3750	1489	1821	1528	1990	1567	2164	1605	2340	1645	2517	1685	2693
4000	1541	2014	1579	2187	1616	2364	1654	2540	1693	2715	1732	2887
4250	1596	2218	1632	2393	1668	2569	1705	2742	1743	2913	---	---
4500	1652	2429	1687	2603	1722	2775	1759	2944	---	---	---	---
4750	1709	2641	1743	2811	1778	2979	---	---	---	---	---	---
5000	1768	2850	---	---	---	---	---	---	---	---	---	---
5250	---	---	---	---	---	---	---	---	---	---	---	---
5500	---	---	---	---	---	---	---	---	---	---	---	---
5750	---	---	---	---	---	---	---	---	---	---	---	---

BLOWER DATA

FACTORY INSTALLED BELT DRIVE KIT SPECIFICATIONS

Nominal hp	Maximum hp	Drive Kit Number	RPM Range
2	2.3	1	590 - 890
2	2.3	2	800 - 1105
2	2.3	3	795 - 1195
3	3.45	4	730 - 970
3	3.45	5	940 - 1200
3	3.45	6	1015 - 1300
5	5.75	10	900 - 1135
5	5.75	11	1040 - 1315
5	5.75	12	1125 - 1425

NOTE - Using total air volume and system static pressure requirements determine from blower performance tables rpm and motor output required. Maximum usable output of motors furnished are shown. In Canada, nominal motor output is also maximum usable motor output. If motors of comparable output are used, be sure to keep within the service factor limitations outlined on the motor nameplate.

NOTE – Units equipped with MSAV® (Multi-Stage Air Volume)option are limited to a motor service factor of 1.0.

POWER EXHAUST FAN PERFORMANCE

Return Air System Static Pressure	Air Volume Exhausted
in. w.g.	cfm
0	3175
0.05	2955
0.10	2685
0.15	2410
0.20	2165
0.25	1920
0.30	1420
0.35	1200

FACTORY INSTALLED OPTIONS/FIELD INSTALLED ACCESSORY AIR RESISTANCE - in. w.g.

Air Volume cfm	Wet Indoor Coil		Electric Heat	Economizer	Filters		Return Air Adaptor Plate
	KHA092	KHA 102,120,150 KHB 092,102,122			MERV 8	MERV 13	
1750	0.03	0.04	0.03	0.05	0.01	0.03	0.00
2000	0.04	0.05	0.03	0.06	0.01	0.03	0.00
2250	0.05	0.06	0.04	0.08	0.01	0.04	0.00
2500	0.05	0.07	0.04	0.11	0.01	0.05	0.00
2750	0.06	0.08	0.05	0.12	0.02	0.05	0.00
3000	0.07	0.10	0.06	0.13	0.02	0.06	0.02
3250	0.08	0.11	0.06	0.15	0.02	0.06	0.02
3500	0.09	0.12	0.09	0.15	0.03	0.07	0.04
3750	0.10	0.14	0.09	0.15	0.03	0.08	0.07
4000	0.11	0.15	0.09	0.19	0.04	0.08	0.09
4250	0.13	0.17	0.13	0.19	0.04	0.09	0.11
4500	0.14	0.19	0.14	0.22	0.04	0.09	0.12
4750	0.15	0.20	0.17	0.25	0.05	0.10	0.16
5000	0.16	0.22	0.20	0.29	0.06	0.10	0.18
5250	0.17	0.24	0.22	0.32	0.06	0.11	0.19
5500	0.19	0.25	0.25	0.34	0.07	0.12	0.22
5750	0.20	0.27	0.31	0.45	0.07	0.12	0.25
6000	0.22	0.29	0.33	0.52	0.08	0.13	0.27

BLOWER DATA

CEILING DIFFUSERS AIR RESISTANCE - in. w.g.

Unit Size	RTD11 Step-Down Diffuser			FD11 Flush Diffuser	
	Air Volume cfm	2 Ends Open	1 Side, 2 Ends Open		All Ends & Sides Open
092 Models	2400	0.21	0.18	0.15	0.14
	2600	0.24	0.21	0.18	0.17
	2800	0.27	0.24	0.21	0.20
	3000	0.32	0.29	0.25	0.25
	3200	0.41	0.37	0.32	0.31
	3400	0.50	0.45	0.39	0.37
	3600	0.61	0.54	0.48	0.44
102,120 & 122 Models	3800	0.73	0.63	0.57	0.51
	3600	0.36	0.28	0.23	0.15
	3800	0.40	0.32	0.26	0.18
	4000	0.44	0.36	0.29	0.21
	4200	0.49	0.40	0.33	0.24
	4400	0.54	0.44	0.37	0.27
	4600	0.60	0.49	0.42	0.31
	4800	0.65	0.53	0.46	0.35
150 Models	5000	0.69	0.58	0.50	0.39
	5200	0.75	0.62	0.54	0.43
	4200	0.22	0.19	0.16	0.10
	4400	0.28	0.24	0.20	0.12
	4600	0.34	0.29	0.24	0.15
	4800	0.40	0.34	0.29	0.19
	5000	0.46	0.39	0.34	0.23
	5200	0.52	0.44	0.39	0.27
5400	0.58	0.49	0.43	0.31	
5600	0.64	0.54	0.47	0.35	
5800	0.70	0.59	0.51	0.39	

CEILING DIFFUSER AIR THROW DATA

Model No.	Air Volume cfm	¹ Effective Throw Range	
		RTD11 Step-Down	FD11 Flush
		ft.	ft.
092 Models	2600	24 - 29	19 - 24
	2800	25 - 30	20 - 28
	3000	27 - 33	21 - 29
	3200	28 - 35	22 - 29
	3400	30 - 37	22 - 30
102,120 & 122 Models	3600	25 - 33	22 - 29
	3800	27 - 35	22 - 30
	4000	29 - 37	24 - 33
	4200	32 - 40	26 - 35
	4400	34 - 42	28 - 37
150 Models	5600	39 - 49	28 - 37
	5800	42 - 51	29 - 38
	6000	44 - 54	40 - 50
	6200	45 - 55	42 - 51
	6400	46 - 55	43 - 52
6600	47 - 56	45 - 56	

¹ Throw is the horizontal or vertical distance an air stream travels on leaving the outlet or diffuser before the maximum velocity is reduced to 50 ft. per minute. Four sides open.

ELECTRICAL/ELECTRIC HEAT DATA - STANDARD EFFICIENCY

7.5 TON

BELT DRIVE BLOWER - kHa092s4

¹ Voltage - 60hz		208/230V - 3 Ph			460V - 3 Ph			575V - 3 Ph		
Compressor 1	Rated Load Amps	13.1			6.1			4.4		
	Locked Rotor Amps	83.1			41			33		
Compressor 2	Rated Load Amps	13.1			6.1			4.4		
	Locked Rotor Amps	83.1			41			33		
Outdoor Fan Motors (2)	Full Load Amps	2.4			1.3			1		
	(total)	(4.8)			(2.6)			(2)		
Power Exhaust (1) 0.33 HP	Full Load Amps	2.4			1.3			1		
Service Outlet 115V GFI (amps)		15			15			20		
Indoor Blower Motor	Horsepower	2	3	5	2	3	5	2	3	5
	Full Load Amps	7.5	10.6	16.7	3.4	4.8	7.6	2.7	3.9	6.1
² Maximum Overcurrent Protection	Unit Only	50	50	60	25	25	30	15	20	20
	With (1) 0.33 HP Power Exhaust	50	60	70	25	25	30	20	20	25
³ Minimum Circuit Ampacity	Unit Only	42	45	52	20	22	25	15	16	19
	With (1) 0.33 HP Power Exhaust	45	48	55	22	23	26	16	17	20

ELECTRIC HEAT DATA

Electric Heat Voltage			208V	240V	208V	240V	208V	240V	480V	480V	480V	600V	600V	600V
² Maximum Overcurrent Protection	Unit+ Electric Heat	7.5 kW	70	70	70	70	80	80	35	35	40	25	25	30
		15 kW	90	90	90	90	100	100	45	45	50	35	35	40
		22.5 kW	110	110	110	125	125	125	60	60	60	45	45	50
		30 kW	125	150	125	150	150	150	70	70	70	60	60	60
		45 kW	175	200	175	200	175	200	90	90	100	70	70	80
³ Minimum Circuit Ampacity	Unit+ Electric Heat	7.5 kW	62	65	65	68	72	75	32	33	36	24	25	28
		15 kW	81	87	84	90	91	97	43	44	47	33	34	37
		22.5 kW	101	110	104	113	111	120	54	55	59	42	43	46
		30 kW	120	132	124	136	131	143	65	67	70	51	52	55
		45 kW	160	178	163	181	170	188	88	89	92	69	70	73
² Maximum Overcurrent Protection	Unit+ Electric Heat and (1) 0.33 HP Power Exhaust	7.5 kW	70	70	70	70	80	80	35	35	40	25	30	30
		15 kW	90	90	90	100	100	100	45	45	50	35	35	40
		22.5 kW	110	125	110	125	125	125	60	60	60	45	45	50
		30 kW	125	150	150	150	150	150	70	70	80	60	60	60
		45 kW	175	200	175	200	175	200	90	100	100	70	80	80
³ Minimum Circuit Ampacity	Unit+ Electric Heat and (1) 0.33 HP Power Exhaust	7.5 kW	64	67	67	70	74	77	33	34	37	25	26	29
		15 kW	84	90	87	93	94	100	44	45	49	34	35	38
		22.5 kW	103	112	106	115	113	122	55	57	60	43	44	47
		30 kW	123	135	126	138	133	145	67	68	71	52	53	56
		45 kW	162	180	165	183	172	190	89	91	94	70	71	74

ELECTRICAL ACCESSORIES

Disconnect	7.5 kW	54W56			54W56			54W56		
	15 kW	54W57			54W56			54W56		
	22.5 kW	54W57			54W56			54W56		
	30 kW	54W57			54W56			54W56		
	45 kW	Not Available			54W57			54W56		

NOTE - All units have a minimum Short Circuit Current Rating (SCCR) of 5000 amps.

¹ Extremes of operating range are plus and minus 10% of line voltage.

² HACR type breaker or fuse.

³ Refer to National or Canadian Electrical Code manual to determine wire, fuse and disconnect size requirements.

ELECTRICAL/ELECTRIC HEAT DATA - STANDARD EFFICIENCY

8.5 TON

BELT DRIVE BLOWER - kHa102s4

¹ Voltage - 60hz		208/230V - 3 Ph			460V - 3 Ph			575V - 3 Ph		
Compressor 1	Rated Load Amps	14.5			6.3			6		
	Locked Rotor Amps	98			55			41		
Compressor 2	Rated Load Amps	14.5			6.3			6		
	Locked Rotor Amps	98			55			41		
Outdoor Fan Motors (2)	Full Load Amps	3			1.5			1.2		
	(total)	(6)			(3)			(2.4)		
Power Exhaust (1) 0.33 HP	Full Load Amps	2.4			1.3			1		
Service Outlet 115V GFI (amps)		15			15			20		
Indoor Blower Motor	Horsepower	2	3	5	2	3	5	2	3	5
	Full Load Amps	7.5	10.6	16.7	3.4	4.8	7.6	2.7	3.9	6.1
² Maximum Overcurrent Protection	Unit Only	60	60	70	25	25	30	20	25	25
	With (1) 0.33 HP Power Exhaust	60	60	70	25	25	30	25	25	25
³ Minimum Circuit Ampacity	Unit Only	47	50	56	21	22	26	19	20	23
	With (1) 0.33 HP Power Exhaust	49	52	59	22	24	27	20	21	24

ELECTRIC HEAT DATA

Electric Heat Voltage			208V	240V	208V	240V	208V	240V	480V	480V	480V	600V	600V	600V
² Maximum Overcurrent Protection	Unit+ Electric Heat	7.5 kW	70	70	70	80	80	90	35	35	40	30	30	35
		15 kW	90	100	90	100	100	110	45	45	50	40	40	45
		22.5 kW	110	125	110	125	125	125	60	60	60	50	50	50
		30 kW	125	150	150	150	150	150	70	70	80	60	60	60
		45 kW	175	200	175	200	175	200	90	90	100	80	80	80
³ Minimum Circuit Ampacity	Unit+ Electric Heat	7.5 kW	66	69	69	72	76	79	32	34	37	28	29	32
		15 kW	86	92	89	95	95	101	44	45	48	37	38	41
		22.5 kW	105	114	108	117	115	124	55	56	59	46	47	50
		30 kW	125	137	128	140	135	147	66	68	71	55	56	59
		45 kW	164	182	167	185	174	192	89	90	93	73	74	77
² Maximum Overcurrent Protection	Unit+ Electric Heat and (1) 0.33 HP Power Exhaust	7.5 kW	70	80	80	80	90	90	35	35	40	30	30	35
		15 kW	90	100	100	100	100	110	45	50	50	40	40	45
		22.5 kW	110	125	125	125	125	150	60	60	70	50	50	60
		30 kW	150	150	150	150	150	150	70	70	80	60	60	60
		45 kW	175	200	175	200	200	200	90	100	100	80	80	80
³ Minimum Circuit Ampacity	Unit+ Electric Heat and (1) 0.33 HP Power Exhaust	7.5 kW	69	72	72	75	78	81	34	35	38	29	30	33
		15 kW	88	94	91	97	98	104	45	46	49	38	39	42
		22.5 kW	108	117	111	120	117	126	56	58	61	47	48	51
		30 kW	127	139	130	142	137	149	67	69	72	56	57	60
		45 kW	166	184	169	187	176	194	90	91	95	74	75	78

ELECTRICAL ACCESSORIES

Disconnect	7.5 kW	54W56	54W56	54W56
	15 kW	54W57	54W56	54W56
	22.5 kW	54W57	54W56	54W56
	30 kW	54W57	54W56	54W56
	45 kW	Not Available	54W57	54W56

NOTE - All units have a minimum Short Circuit Current Rating (SCCR) of 5000 amps.

¹ Extremes of operating range are plus and minus 10% of line voltage.

² HACR type breaker or fuse.

³ Refer to National or Canadian Electrical Code manual to determine wire, fuse and disconnect size requirements.

ELECTRICAL/ELECTRIC HEAT DATA - STANDARD EFFICIENCY

10 TON

BELT DRIVE BLOWER - kHa120s4

¹ Voltage - 60hz		208/230V - 3 Ph			460V - 3 Ph			575V - 3 Ph		
Compressor 1	Rated Load Amps	15.6			7.8			5.8		
	Locked Rotor Amps	110			52			38.9		
Compressor 2	Rated Load Amps	15.6			7.8			5.8		
	Locked Rotor Amps	110			52			38.9		
Outdoor Fan Motors (2)	Full Load Amps	3			1.5			1.2		
	(total)	(6)			(3)			(2.4)		
Power Exhaust (1) 0.33 HP	Full Load Amps	2.4			1.3			1		
Service Outlet 115V GFI (amps)		15			15			20		
Indoor Blower Motor	Horsepower	2	3	5	2	3	5	2	3	5
	Full Load Amps	7.5	10.6	16.7	3.4	4.8	7.6	2.7	3.9	6.1
² Maximum Overcurrent Protection	Unit Only	60	60	70	30	30	35	20	25	25
	With (1) 0.33 HP Power Exhaust	60	60	70	30	30	35	20	25	25
³ Minimum Circuit Ampacity	Unit Only	49	52	59	24	26	29	19	20	22
	With (1) 0.33 HP Power Exhaust	51	55	61	26	27	30	20	21	23

ELECTRIC HEAT DATA

Electric Heat Voltage			208V	240V	208V	240V	208V	240V	480V	480V	480V	600V	600V	600V
² Maximum Overcurrent Protection	Unit+ Electric Heat	15 kW	90	100	100	100	100	110	50	50	60	40	40	40
		22.5 kW	110	125	125	125	125	150	60	60	70	50	50	50
		30 kW	150	150	150	150	150	150	70	80	80	60	60	60
		45 kW	175	200	175	200	200	200	100	100	100	80	80	80
		60 kW	175	200	200	200	200	225	100	100	110	80	80	80
³ Minimum Circuit Ampacity	Unit+ Electric Heat	15 kW	88	94	91	97	98	104	47	48	51	37	38	40
		22.5 kW	108	117	111	120	117	126	58	60	62	46	47	49
		30 kW	127	139	130	142	137	149	70	71	74	55	56	58
		45 kW	166	184	169	188	176	194	92	94	96	73	74	76
		60 kW	174	193	177	197	184	203	97	98	101	76	78	80
² Maximum Overcurrent Protection	Unit+ Electric Heat and (1) 0.33 HP Power Exhaust	15 kW	100	100	100	100	100	110	50	50	60	40	40	45
		22.5 kW	110	125	125	125	125	150	60	70	70	50	50	50
		30 kW	150	150	150	150	150	175	80	80	80	60	60	60
		45 kW	175	200	175	200	200	200	100	100	100	80	80	80
		60 kW	200	200	200	200	200	225	100	100	110	80	80	90
³ Minimum Circuit Ampacity	Unit+ Electric Heat and (1) 0.33 HP Power Exhaust	15 kW	91	97	94	100	100	106	48	50	53	38	39	41
		22.5 kW	110	119	113	122	120	129	60	61	64	47	48	50
		30 kW	130	142	133	145	139	151	71	72	75	56	57	59
		45 kW	169	187	172	190	178	196	93	95	98	74	75	77
		60 kW	177	196	180	199	186	205	98	99	102	77	79	81

ELECTRICAL ACCESSORIES

Disconnect	15 kW	54W57			54W56			54W56		
	22.5 kW	54W57			54W56			54W56		
	30 kW	54W57			54W56			54W56		
	45 kW	Not Available			54W57			54W56		
	60 kW	Not Available			54W57			54W56		

NOTE - All units have a minimum Short Circuit Current Rating (SCCR) of 5000 amps.

¹ Extremes of operating range are plus and minus 10% of line voltage.

² HACR type breaker or fuse.

³ Refer to National or Canadian Electrical Code manual to determine wire, fuse and disconnect size requirements.

ELECTRICAL/ELECTRIC HEAT DATA - STANDARD EFFICIENCY

12.5 TON

BELT DRIVE BLOWER - KHA150S4

¹ Voltage - 60hz		208/230V - 3 Ph			460V - 3 Ph			575V - 3 Ph		
Compressor 1	Rated Load Amps	19			9.7			7.4		
	Locked Rotor Amps	123			62			50		
Compressor 2	Rated Load Amps	19			9.7			7.4		
	Locked Rotor Amps	123			62			50		
Outdoor Fan Motors (3)	Full Load Amps	2.4			1.3			1		
	(total)	(7.2)			(3.9)			(3)		
Power Exhaust (3) 0.33 HP	Full Load Amps	2.4			1.3			1		
Service Outlet 115V GFI (amps)		15			15			20		
Indoor Blower Motor	Horsepower	2	3	5	2	3	5	2	3	5
	Full Load Amps	7.5	10.6	16.7	3.4	4.8	7.6	2.7	3.9	6.1
² Maximum Overcurrent Protection	Unit Only	70	70	80	35	40	40	25	30	30
	With (1) 0.33 HP Power Exhaust	80	80	90	40	40	45	30	30	35
³ Minimum Circuit Ampacity	Unit Only	58	61	67	30	31	34	23	24	26
	With (1) 0.33 HP Power Exhaust	65	68	74	34	35	38	26	27	29

ELECTRIC HEAT DATA

Electric Heat Voltage			208V	240V	208V	240V	208V	240V	480V	480V	480V	600V	600V	600V
² Maximum Overcurrent Protection	Unit+ Electric Heat	15 kW	100	110	110	110	110	125	60	60	60	45	45	45
		22.5 kW	125	150	125	150	150	150	70	70	70	50	60	60
		30 kW	150	150	150	175	150	175	80	80	80	60	60	70
		45 kW	175	200	200	200	200	225	100	100	110	80	80	80
		60 kW	200	225	200	225	200	225	110	110	110	90	90	90
³ Minimum Circuit Ampacity	Unit+ Electric Heat	15 kW	97	103	100	106	106	112	52	54	56	41	42	44
		22.5 kW	117	126	120	129	126	135	63	65	68	50	51	53
		30 kW	136	148	139	151	145	157	75	76	79	59	60	62
		45 kW	175	193	178	196	184	202	97	99	101	77	78	80
		60 kW	183	202	186	205	192	211	102	103	106	81	82	84
² Maximum Overcurrent Protection	Unit+ Electric Heat and (1) 0.33 HP Power Exhaust	15 kW	110	110	110	125	125	125	60	60	60	45	45	50
		22.5 kW	125	150	150	150	150	150	70	70	80	60	60	60
		30 kW	150	175	150	175	175	175	80	80	90	70	70	70
		45 kW	200	200	200	225	200	225	110	110	110	80	90	90
		60 kW	200	225	200	225	200	225	110	110	110	90	90	90
³ Minimum Circuit Ampacity	Unit+ Electric Heat and (1) 0.33 HP Power Exhaust	15 kW	104	110	107	113	113	119	56	57	60	44	45	47
		22.5 kW	124	133	127	136	133	142	67	69	72	53	54	56
		30 kW	143	155	146	158	153	165	79	80	83	62	63	65
		45 kW	182	200	186	204	192	210	101	103	105	80	81	83
		60 kW	190	209	193	213	199	219	106	107	110	84	85	87

ELECTRICAL ACCESSORIES

Disconnect	15 kW	54W57	54W56	54W56
	22.5 kW	54W57	54W56	54W56
	30 kW	Not Available	54W56	54W56
	45 kW	Not Available	54W57	54W57
	60 kW	Not Available	54W57	54W57

NOTE - All units have a minimum Short Circuit Current Rating (SCCR) of 5000 amps.

¹ Extremes of operating range are plus and minus 10% of line voltage.

² HACR type breaker or fuse.

³ Refer to National or Canadian Electrical Code manual to determine wire, fuse and disconnect size requirements.

ELECTRICAL/ELECTRIC HEAT DATA - HIGH EFFICIENCY

7.5 TON

BELT DRIVE BLOWER - KHB092H4

¹ Voltage - 60hz		208/230V - 3 Ph			460V - 3 Ph			575V - 3 Ph		
Compressor 1	Rated Load Amps	13.1			6.1			4.4		
	Locked Rotor Amps	83.1			41			33		
Compressor 2	Rated Load Amps	13.1			6.1			4.4		
	Locked Rotor Amps	83.1			41			33		
Outdoor Fan Motors (2)	Full Load Amps	2.8			1.4			1.1		
	(total)	(5.6)			(2.8)			(2.2)		
Power Exhaust (1) 0.33 HP	Full Load Amps	2.4			1.3			1		
Service Outlet 115V GFI (amps)		15			15			20		
Indoor Blower Motor	Horsepower	2	3	5	2	3	5	2	3	5
	Full Load Amps	7.5	10.6	16.7	3.4	4.8	7.6	2.7	3.9	6.1
² Maximum Overcurrent Protection	Unit Only	50	50	60	25	25	30	15	20	20
	With (1) 0.33 HP Power Exhaust	50	60	70	25	25	30	20	20	25
³ Minimum Circuit Ampacity	Unit Only	43	46	53	20	22	25	15	16	19
	With (1) 0.33 HP Power Exhaust	45	49	56	22	23	26	16	17	20

ELECTRIC HEAT DATA

Electric Heat Voltage			208V	240V	208V	240V	208V	240V	480V	480V	480V	600V	600V	600V
² Maximum Overcurrent Protection	Unit+ Electric Heat	7.5 kW	70	70	70	70	80	80	35	35	40	25	30	30
		15 kW	90	90	90	100	100	100	45	45	50	35	35	40
		22.5 kW	110	125	110	125	125	125	60	60	60	45	45	50
		30 kW	125	150	125	150	150	150	70	70	70	60	60	60
		45 kW	175	200	175	200	175	200	90	90	100	70	80	80
³ Minimum Circuit Ampacity	Unit+ Electric Heat	7.5 kW	63	66	66	69	73	76	32	33	36	24	26	28
		15 kW	82	88	85	91	92	98	43	44	48	33	35	37
		22.5 kW	102	111	105	114	112	121	54	56	59	42	44	46
		30 kW	121	133	124	136	131	143	66	67	70	51	53	55
		45 kW	160	178	163	181	170	188	88	89	93	69	71	73
² Maximum Overcurrent Protection	Unit+ Electric Heat and (1) 0.33 HP Power Exhaust	7.5 kW	70	70	70	80	80	80	35	35	40	25	30	30
		15 kW	90	100	90	100	100	110	45	50	50	35	40	40
		22.5 kW	110	125	110	125	125	125	60	60	60	45	45	50
		30 kW	125	150	150	150	150	150	70	70	80	60	60	60
		45 kW	175	200	175	200	175	200	90	100	100	70	80	80
³ Minimum Circuit Ampacity	Unit+ Electric Heat and (1) 0.33 HP Power Exhaust	7.5 kW	65	68	68	71	75	78	33	34	38	25	27	29
		15 kW	85	91	88	94	95	101	44	46	49	34	36	38
		22.5 kW	104	113	107	116	114	123	56	57	60	43	45	47
		30 kW	124	136	127	139	134	146	67	68	71	52	54	56
		45 kW	163	181	166	184	173	191	89	91	94	70	72	74

ELECTRICAL ACCESSORIES

Disconnect	7.5 kW	54W56			54W56			54W56		
	15 kW	54W57			54W56			54W56		
	22.5 kW	54W57			54W56			54W56		
	30 kW	54W57			54W56			54W56		
	45 kW	Not Available			54W57			54W56		

NOTE - All units have a minimum Short Circuit Current Rating (SCCR) of 5000 amps.

¹ Extremes of operating range are plus and minus 10% of line voltage.

² HACR type breaker or fuse.

³ Refer to National or Canadian Electrical Code manual to determine wire, fuse and disconnect size requirements.

ELECTRICAL/ELECTRIC HEAT DATA - HIGH EFFICIENCY

8.5 TON

BELT DRIVE BLOWER - KHB102H4

¹ Voltage - 60hz		208/230V - 3 Ph			460V - 3 Ph			575V - 3 Ph		
Compressor 1	Rated Load Amps	14.5			6.3			6		
	Locked Rotor Amps	98			55			41		
Compressor 2	Rated Load Amps	14.5			6.3			6		
	Locked Rotor Amps	98			55			41		
Outdoor Fan Motors (2)	Full Load Amps	2.8			1.4			1.1		
	(total)	(5.6)			(2.8)			(2.2)		
Power Exhaust (1) 0.33 HP	Full Load Amps	2.4			1.3			1		
Service Outlet 115V GFI (amps)		15			15			20		
Indoor Blower Motor	Horsepower	2	3	5	2	3	5	2	3	5
	Full Load Amps	7.5	10.6	16.7	3.4	4.8	7.6	2.7	3.9	6.1
² Maximum Overcurrent Protection	Unit Only	60	60	70	25	25	30	20	25	25
	With (1) 0.33 HP Power Exhaust	60	60	70	25	25	30	25	25	25
³ Minimum Circuit Ampacity	Unit Only	46	49	56	21	22	25	19	20	22
	With (1) 0.33 HP Power Exhaust	49	52	58	22	24	27	20	21	23

ELECTRIC HEAT DATA

Electric Heat Voltage			208V	240V	208V	240V	208V	240V	480V	480V	480V	600V	600V	600V
² Maximum Overcurrent Protection	Unit+ Electric Heat	7.5 kW	70	70	70	80	80	90	35	35	40	30	30	35
		15 kW	90	100	90	100	100	110	45	45	50	40	40	40
		22.5 kW	110	125	110	125	125	125	60	60	60	50	50	50
		30 kW	125	150	150	150	150	150	70	70	80	60	60	60
		45 kW	175	200	175	200	175	200	90	90	100	80	80	80
³ Minimum Circuit Ampacity	Unit+ Electric Heat	7.5 kW	66	69	69	72	76	79	32	34	37	28	29	31
		15 kW	85	91	88	94	95	101	43	45	48	37	38	40
		22.5 kW	105	114	108	117	115	124	55	56	59	46	47	49
		30 kW	124	136	128	140	134	146	66	67	71	55	56	58
		45 kW	163	182	167	185	173	191	89	90	93	73	74	76
² Maximum Overcurrent Protection	Unit+ Electric Heat and (1) 0.33 HP Power Exhaust	7.5 kW	70	80	80	80	90	90	35	35	40	30	30	35
		15 kW	90	100	100	100	100	110	45	50	50	40	40	45
		22.5 kW	110	125	110	125	125	150	60	60	70	50	50	50
		30 kW	150	150	150	150	150	150	70	70	80	60	60	60
		45 kW	175	200	175	200	200	200	90	100	100	80	80	80
³ Minimum Circuit Ampacity	Unit+ Electric Heat and (1) 0.33 HP Power Exhaust	7.5 kW	68	71	71	74	78	81	33	35	38	29	30	32
		15 kW	88	94	91	97	97	103	45	46	49	38	39	41
		22.5 kW	107	116	110	119	117	126	56	57	61	47	48	50
		30 kW	127	139	130	142	137	149	67	69	72	56	57	59
		45 kW	166	184	169	187	176	194	90	91	94	74	75	77

ELECTRICAL ACCESSORIES

Disconnect	7.5 kW	54W56			54W56			54W56		
	15 kW	54W57			54W56			54W56		
	22.5 kW	54W57			54W56			54W56		
	30 kW	54W57			54W56			54W56		
	45 kW	Not Available			54W57			54W56		

NOTE - All units have a minimum Short Circuit Current Rating (SCCR) of 5000 amps.

¹ Extremes of operating range are plus and minus 10% of line voltage.

² HACR type breaker or fuse.

³ Refer to National or Canadian Electrical Code manual to determine wire, fuse and disconnect size requirements.

ELECTRICAL/ELECTRIC HEAT DATA - HIGH EFFICIENCY

10 TON

DIRECT DRIVE BLOWER - kHB122H4

¹ Voltage - 60hz		208/230V - 3 Ph	460V - 3 Ph	575V - 3 Ph
Compressor 1	Rated Load Amps	15.6	7.8	5.8
	Locked Rotor Amps	110	52	38.9
Compressor 2	Rated Load Amps	15.6	7.8	5.8
	Locked Rotor Amps	110	52	38.9
Outdoor Fan Motors (3)	Full Load Amps	2.8	1.4	1.1
	(total)	(8.4)	(4.2)	(3.3)
Power Exhaust (1) 0.33 HP	Full Load Amps	2.4	1.3	1
Service Outlet 115V GFI (amps)		15	15	20
Indoor Blower Motor	Horsepower	3.75	3.75	3.75
	Full Load Amps	8.8	4.3	3.4
² Maximum Overcurrent Protection	Unit Only	60	30	25
	With (1) 0.33 HP Power Exhaust	70	35	25
³ Minimum Circuit Ampacity	Unit Only	53	27	20
	With (1) 0.33 HP Power Exhaust	60	30	23

ELECTRIC HEAT DATA

Electric Heat Voltage			208V	240V	480V	600V
² Maximum Overcurrent Protection	Unit+ Electric Heat	15 kW	100	100	50	40
		22.5 kW	125	125	60	50
		30 kW	150	150	80	60
		45 kW	175	200	100	80
		60 kW	200	200	100	80
³ Minimum Circuit Ampacity	Unit+ Electric Heat	15 kW	92	98	49	38
		22.5 kW	111	120	60	47
		30 kW	131	143	72	56
		45 kW	170	188	94	74
		60 kW	178	197	99	78
² Maximum Overcurrent Protection	Unit+ Electric Heat and (1) 0.33 HP Power Exhaust	15 kW	100	110	60	45
		22.5 kW	125	150	70	50
		30 kW	150	150	80	60
		45 kW	200	200	100	80
		60 kW	200	225	110	90
³ Minimum Circuit Ampacity	Unit+ Electric Heat and (1) 0.33 HP Power Exhaust	15 kW	99	105	53	41
		22.5 kW	119	128	64	50
		30 kW	138	150	76	59
		45 kW	177	195	98	77
		60 kW	185	204	103	81

ELECTRICAL ACCESSORIES

Disconnect	15 kW	54W57	54W56	54W56
	22.5 kW	54W57	54W56	54W56
	30 kW	54W57	54W56	54W56
	45 kW	Not Available	54W57	54W57
	60 kW	Not Available	54W57	54W57

NOTE - All units have a minimum Short Circuit Current Rating (SCCR) of 5000 amps.

¹ Extremes of operating range are plus and minus 10% of line voltage.

² HACR type breaker or fuse.

³ Refer to National or Canadian Electrical Code manual to determine wire, fuse and disconnect size requirements.

ELECTRIC HEAT CAPACITIES

Volts Input	7.5 kW			15 kW			22.5 kW			30 kW			45 kW			60 kW		
	kW Input	Btuh Output	No. of Stages	kW Input	Btuh Output	No. of Stages	kW Input	Btuh Output	No. of Stages	kW Input	Btuh Output	No. of Stages	kW Input	Btuh Output	No. of Stages	kW Input	Btuh Output	No. of Stages
208	5.6	19,100	1	11.3	38,600	1	16.9	57,700	2	22.5	76,800	2	33.8	115,300	2	45.0	153,600	2
220	6.3	21,500	1	12.6	43,000	1	18.9	64,500	2	25.2	86,000	2	37.8	129,000	2	50.4	172,000	2
230	6.9	23,600	1	13.8	47,100	1	20.7	70,700	2	27.5	93,900	2	41.3	141,000	2	55.1	188,000	2
240	7.5	25,600	1	15.0	51,200	1	22.5	76,800	2	30.0	102,400	2	45.0	153,600	2	60.0	204,800	2
440	6.9	21,500	1	12.6	43,000	1	18.9	64,500	2	25.2	86,000	2	37.8	129,000	2	50.4	172,000	2
460	6.9	23,600	1	13.8	47,100	1	20.7	70,700	2	27.5	93,900	2	41.3	141,000	2	55.1	188,000	2
480	7.5	25,600	1	15.0	51,200	1	22.5	76,800	2	30.0	102,400	2	45.0	153,600	2	60.0	204,800	2
550	6.3	21,500	1	12.6	43,000	1	18.9	64,500	2	25.2	86,000	2	37.8	129,000	2	50.4	172,000	2
575	6.9	23,600	1	13.8	47,100	1	20.7	70,700	2	27.5	93,900	2	41.3	141,000	2	55.1	188,000	2
600	7.5	25,600	1	15.0	51,200	1	22.5	76,800	2	30.0	102,400	2	45.0	153,600	2	60.0	204,800	2

KHA/KHB PARTS ARRANGEMENT

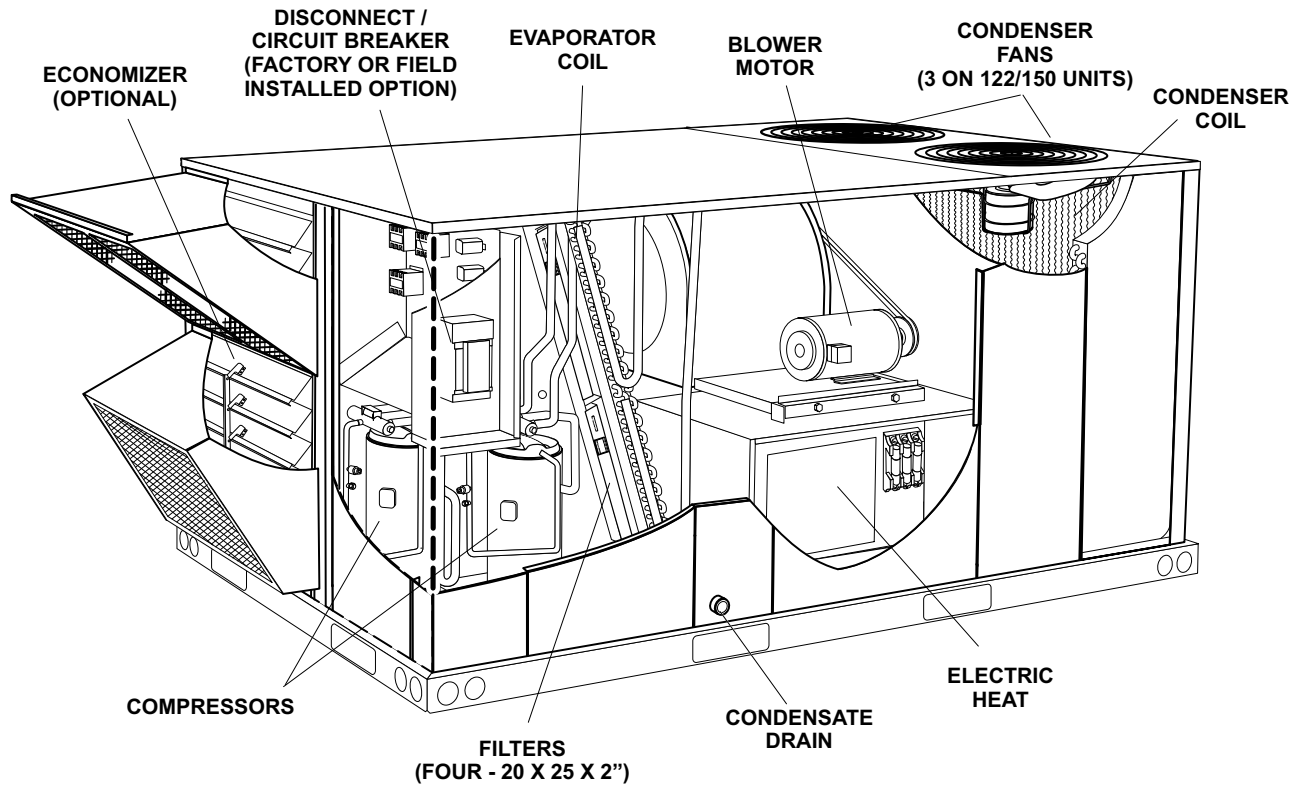

FIGURE 1

KHA092/102/120/150 CONTROL BOX

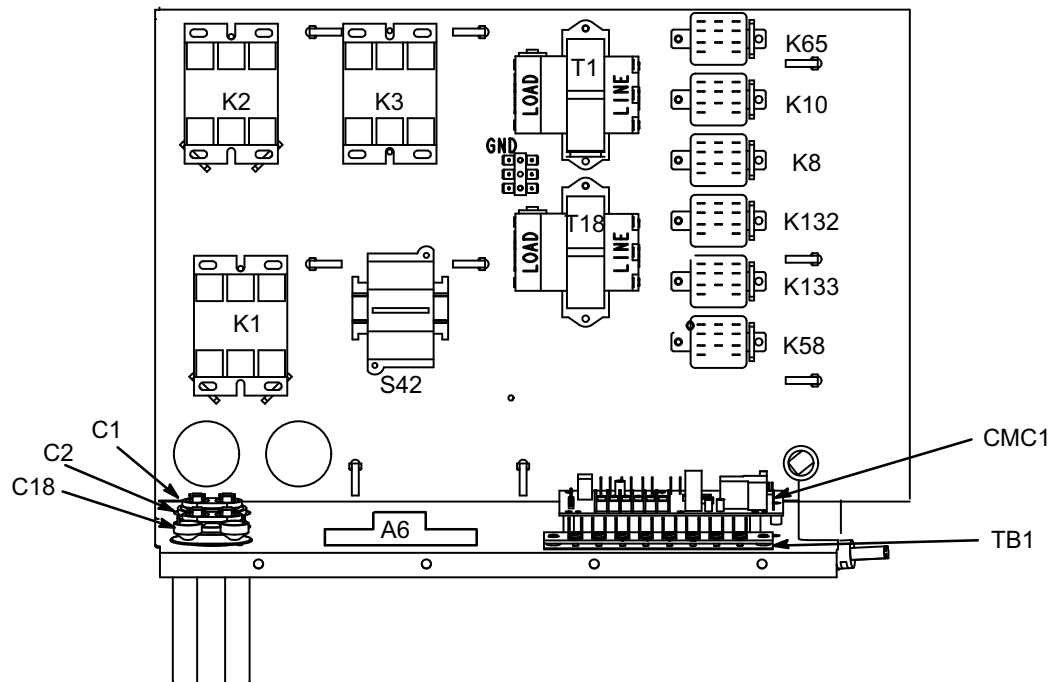

FIGURE 2

KHB092/102/122 CONTROL BOX

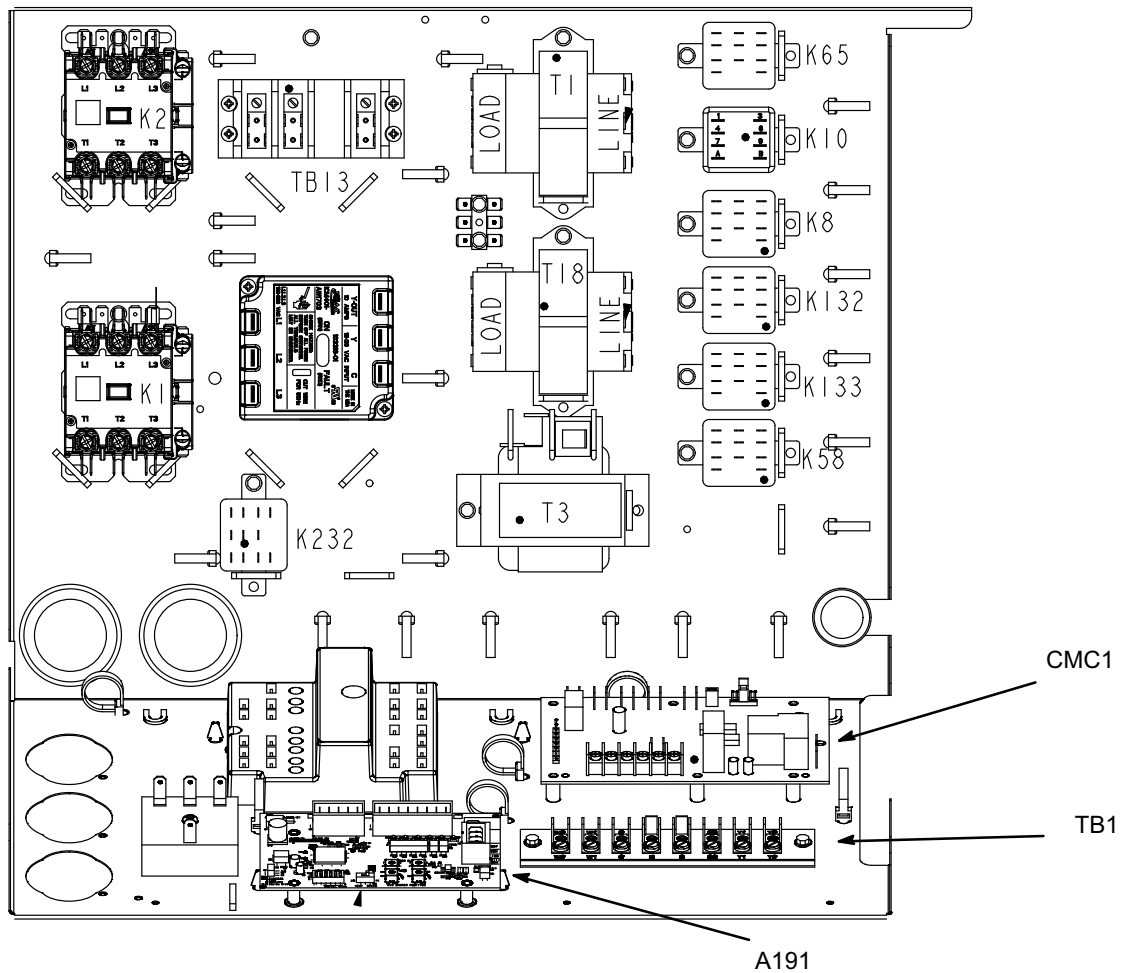

FIGURE 3

I-UNIT COMPONENTS

The KHA/KHB unit parts arrangement are shown in figure 1. All L1, L2, and L3 wiring is color coded; L1 is red, L2 is yellow, and L3 is blue. See wiring diagrams in the back of this manual for complete call out of components per KHA/KHB unit.

A-Control Box Components

KHA control box components are shown in figure 2 and KHB control box components are shown in figure 3. The control box is located in the upper portion of the compressor compartment.

1-Disconnect Switch S48 (field installed)

KHA/KHB units may be equipped with an optional disconnect switch S48. S48 is a toggle switch, which can be used by the service technician to disconnect power to the unit.

2-Transformer T1

All KHA/KHB series units use a single line voltage to 24VAC transformer mounted in the control box. Transformer supplies power to CMC1 and control circuits in the unit. The transformer is rated at 70VA and is pro-

tected by a 3.5 amp circuit breaker (CB8). The 208/230V

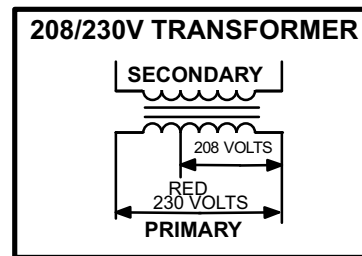

FIGURE 4

3-Transformer T18

T18 is a single line voltage to 24VAC transformer used in all KHA/KHB units. T18 is identical to T1 and is protected by a 3.5 amp circuit breaker (CB18). T18 provides 24VAC to K1 and K2 coil and reversing valve L1 and L2 (via K58-1 contacts).

4-Outdoor Fan Capacitor C1, C2, and C18 (KHA Only)

Fan capacitors C1, C2, and C18 are 370V/10MF capacitors used to assist in the start up of condenser fan motors B4, B5, and B21. Capacitor ratings will be on outdoor fan motor nameplate.

5-Compressor Contactor K1 & K2

All compressor contactors are three-pole-double-break contactors with a 24VAC coil. In all KHA/KHB units, K1 and K2 energize compressors B1 and B2 respectively in response to first or second stage cooling demands. For KHB units, the auxiliary contacts are attached that disable the crankcase heaters when compressor is energized. On KHA CE M-volt units, contactor is CE approved by manufacturer (Siemens). See figure 5.

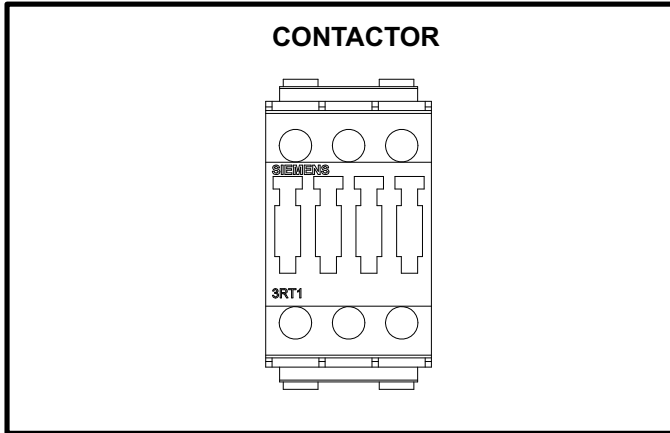

FIGURE 5

6-Blower Contactor K3

Blower contactor K3, used in all KHA/KHB CAV units, is a three-pole-double-break contactor with a 24VAC coil used to energize the indoor blower motor B3 in response to blower demand. K3 is energized by a thermostat cooling demand. On M-volt KHA CE units, the contactor is CE approved by manufacturer (Siemens). See figure 5.

7-Outdoor Fan Relay K10

Outdoor fan relay K10 is a DPDT relay with a 24VAC coil. K10 energizes condenser fan motors B4, B5, and B21 (KHA150 and KHB122 only) in response to a W1 heating or Y1 or Y2 cooling demand.

8-Power Exhaust Relay K65 (PED units)

Power exhaust relay K65 is a N.O. DPDT relay with a 24VAC coil. K65 is used in all KHA/KHB units equipped with the optional power exhaust dampers. K65 is energized by the economizer control panel (A6), after the economizer dampers reach 50% open (adjustable on control A6). When K65 closes, the exhaust fan B10 is energized.

9-Compressor On Relays (K132 & K133)

K132 and K133 are two-pole relays with a 24V coil used to energize compressor contactor coils. K1 is energized by K132 with a Y1 demand. K2 is energized by K133 with a Y2 demand. Both K1 and K2 are energized by K132 and K133 with a W1 demand.

10-Transfer Relay (K8)

K8 is a three-pole relay with a 24V coil used to de-energize the reversing valve during a heating demand. On a first-stage demand K8-1 closes de-energizing the reversing valve. K8-2 closes energizing Y1 on the CMC1 board. Without K8 the reversing valve would remain energized at all times.

11-Low Ambient Kit Relay (K58)

Low ambient relay K58 is a DPDT relay with a 24V coil energized by a CMC1 output in the heating cycle. K58-1 closes to allow power to reversing valves L1 and L2. K58-2 closes to bypass S11 and S84. This allows the fan to operate during the heating demand and cycle during the cooling demand.

12-Blower Motor Overload Relay Switch (S42)

The blower motor overload relay is used in all units equipped with high efficiency motors. The relay (S42) is connected in line with the blower motor to monitor the current flow to the motor. When the relay senses an overload condition, a set of normally closed contacts open to de-energize 24VAC power T1 transformer.

13-Terminal Block (TB1)

TB1 provides 24VAC field connections. All indoor thermostat connections are connected to TB1 located in the control box.

14-Compressor Overload Relays S176, S177 (M-volt CE units)

Relays are wired in series with the appropriate compressor contactor and monitor the current flow to the compressor motor. When the relay senses an overload condition, N.C. contacts open to de-energize the compressor. Relays are manufactured by Siemens; see figure 6.

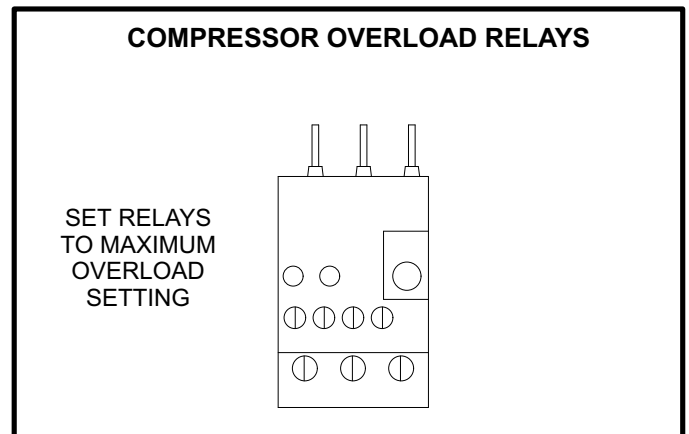

FIGURE 6

15-Enthalpy Control (A6)

Refer to description in economizer section.

16-Defrost Control Board CMC1 29M01

The defrost thermostat, defrost pressure switch and the defrost control work together to ensure that the heat pump outdoor coil does not ice excessively during the heating mode.

Compressor Accumulated Run-Time Interval

The defrost control will not energize a defrost cycle unless the unit has been operating in heating mode for an accumulated 60 minutes (default). The run time interval can be changed by moving the jumper on the CMC board timing pins. See figure 7.

The defrost interval can be adjusted to 30, 60, or 90 minutes. The defrost timing jumper is factory-installed to provide a 60-minute defrost interval. If the timing selector jumper is not in place, the control defaults to a 90-minute defrost interval.

Defrost Test Option

A TEST option is provided for troubleshooting. The TEST mode may be started any time the unit is in the heating mode and the defrost thermostat is closed or jumpered. If the timing jumper is in the TEST position at power-up, the

defrost control will ignore the test pins. When the jumper is placed across the TEST pins for two seconds, the control will enter the defrost mode. If the jumper is removed before an additional 5-second period has elapsed (7 seconds total), the unit will remain in defrost mode until the defrost pressure switch opens or 14 minutes have passed. If the jumper is not removed until after the additional 5-second period has elapsed, the defrost will terminate and the test option will not function again until the jumper is removed and re-applied.

Diagnostic LEDs

The defrost board uses two LEDs for diagnostics. The LEDs flash a sequence according to the condition.

TABLE 1

Defrost Control Board Diagnostic LED		
Indicates	LED 1	LED 2
Normal operation / power to board	Synchronized Flash with LED 2	Synchronized Flash with LED 1
Board failure / no power	Off	Off
Board failure	On	On
Pressure switch open	Flash	On

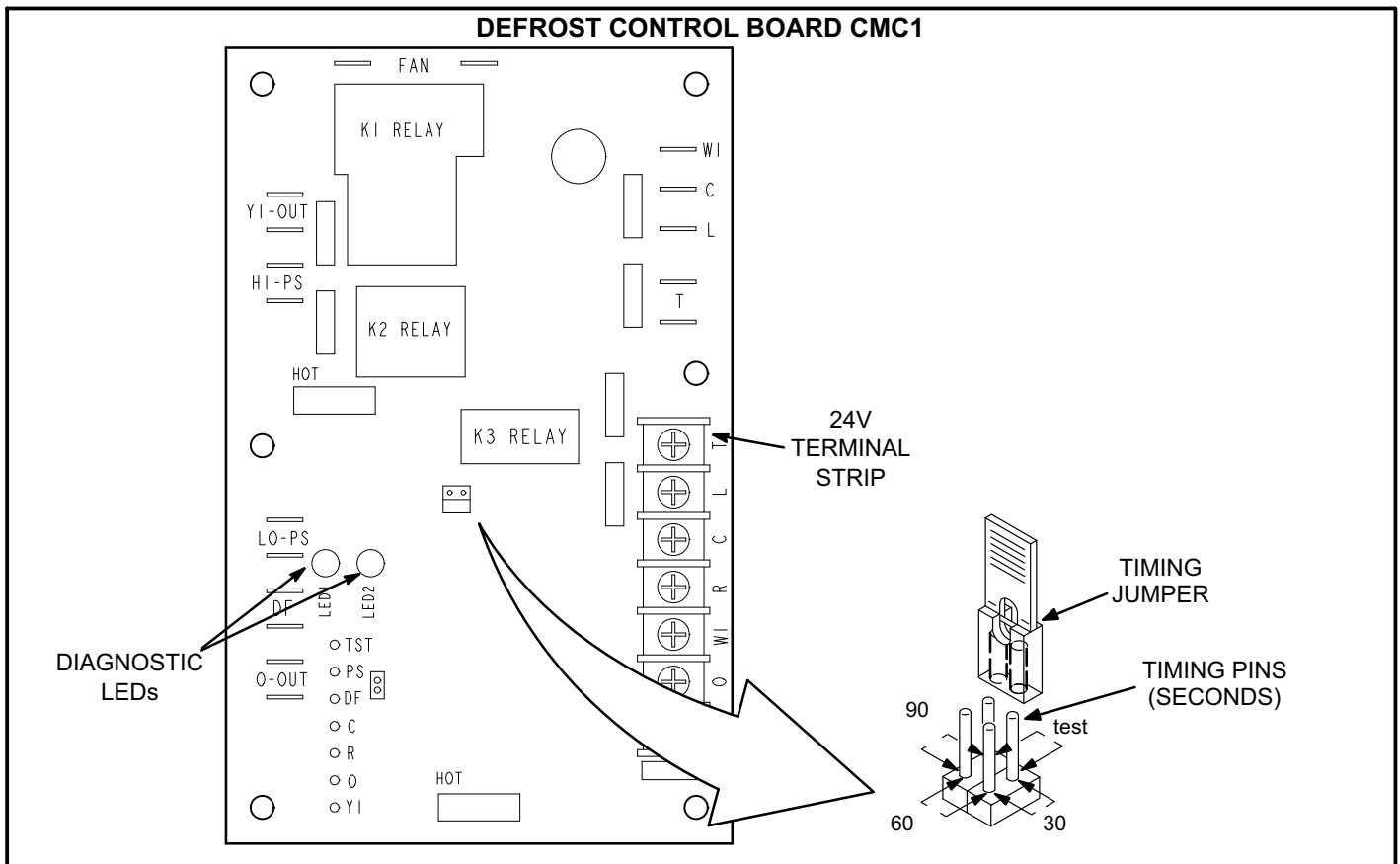

FIGURE 7

17-Defrost Control Board CMC1 100269-05

The defrost system includes a defrost thermostat and a defrost control.

DEFROST THERMOSTAT

The defrost thermostat is located on the liquid line between the check/expansion valve and the distributor. When the defrost thermostat senses 42°F (5.5°C) or cooler, its contacts close and send a signal to the defrost control to start the defrost timing. It also terminates defrost when the liquid line warms up to 70°F (21°C).

DEFROST CONTROL (CMC1)

The defrost control includes the combined functions of a time/temperature defrost control, defrost relay, time delay, diagnostic LEDs, and a terminal strip for field wiring connections.

The control provides automatic switching from normal heating operation to defrost mode and back. During compressor cycle (defrost thermostat is closed, calling for defrost), the control accumulates compressor run times at 30, 60, or 90 minute field adjustable intervals. If the defrost thermostat is closed when the selected compressor run time interval ends, the defrost relay is energized and defrost begins.

Defrost Control Timing Pins (P1)

Each timing pin selection provides a different accumulated compressor run time period for one defrost cycle. This time period must occur before a defrost cycle is initiated. The defrost interval can be adjusted to 30 (T1), 60 (T2), or 90 (T3) minutes (see figure 8). The maximum defrost period is 14 minutes and cannot be adjusted. Factory default is 90 minutes

If the timing selector jumper is missing, the defrost control defaults to a 90-minute defrost interval.

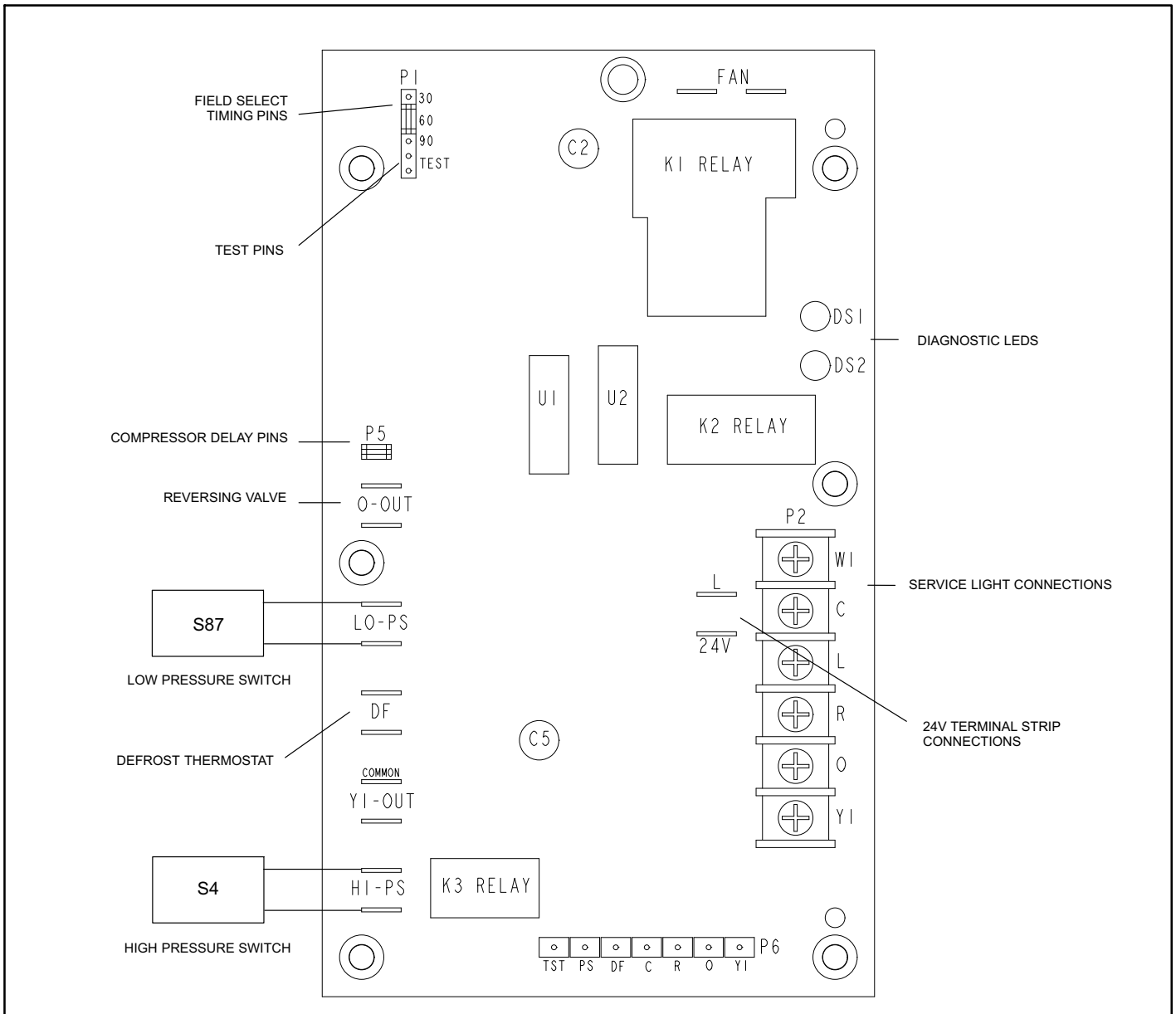

FIGURE 8

Test Mode

The **TEST** mode is activated by removing the jumper on the defrost termination pins (**30**, **60** or **90**) and placing the jumper on the **TEST** pins after 24VAC is applied to the control. The low pressure input is ignored in **TEST** mode.

IMPORTANT

The **TEST** pins are ignored and the **TEST** function is locked out:

- If the jumper is applied on the **TEST** pin before 24VAC is applied to the control.
- If there is a jumper on the 30 or 60 minute defrost termination pins.

Bypass-Anti-Short Cycle Delay

The **Y1** input must be active **ON**, the high pressure switch must be closed or a jumper must be installed on the high pressure terminals of the control.

Initiate a Forced Defrost

The **Y1** input must be active **ON**, the high pressure switch must be closed or a jumper must be installed on the high pressure terminals of the control, the defrost thermostat must be closed or a jumper must be placed across the **DF** terminals on the control and the **O** terminals must not have 24VAC (no power to reversing valve) before control will enter into a force defrost.

Test Mode Sequence

Using the defrost termination pin, short the **TEST** pins for a period of two seconds:

- Clear timed lockout / or pressure switch lockout function.
- Enter defrost mode

After entering forced defrost, if the jumper is removed before 5 seconds has elapsed, the unit will remain in forced defrost mode until defrost thermostat opens or terminated on maximum defrost time (14 minutes). If the jumper is not removed, once 5 seconds has elapsed (7 seconds total), the unit will terminate defrost and return to heat mode. The **TEST** mode will then be locked-out and no further **TEST** mode operation will be executed until the jumper on the **TEST** pins is removed and re-applied to the applicable defrost termination pins.

IMPORTANT

NOTE - After testing has been completed, properly reposition test jumper across desired timing pins.

Compressor Delay (P5)

The 100269-05 control, with the 30 second field-selectable delay, is active when the pins are jumpered. This feature helps reduce occasional sounds that may occur while the unit is cycling **In** and **Out** of the defrost mode.

NOTE — The 30-second compressor feature is ignored when jumper is installed on **TEST** pins.

Compressor Anti-Short-Cycle Delay

The timed-off delay is five minutes long. The delay helps protect the compressor from short-cycling in case the power to the unit is interrupted or a pressure switch opens. The delay is bypassed by placing the timer select jumper across the **TEST** pins for 0.5 seconds.

NOTE - The defrost control must have a thermostat demand for the bypass function to operate

Pressure Switch Circuits

The defrost control includes two pressure switch circuits. The factory-installed high pressure switch (S4) wires are connected to the defrost control's HI PS terminals (figure 8). The defrost control also includes LO PS terminals to accommodate an optional field-provided low (or loss-of-charge) pressure switch.

During a single thermostat cycle, the defrost control will lock out the unit after the fifth time that the circuit is interrupted by any pressure switch that is wired to the defrost control. In addition, the diagnostic LEDs will indicate a pressure switch lockout after the fifth occurrence of an open pressure switch (see table 2). The unit will remain locked out until 24V power from the indoor unit is broken then remade to the control or until the jumper is applied to the **TEST** pins for 0.5 seconds.

NOTE - The defrost control ignores input from the low pressure switch terminals during the **TEST** mode, during the defrost cycle, during the 90-second start-up period, and for the first 90 seconds each time the reversing valve switches heat/cool modes. **If the TEST pins are jumpered and the 5-minute delay is being bypassed, the LO PS terminal signal is not ignored during the 90-second start-up period.**

DIAGNOSTIC LEDs

The defrost control uses two LEDs for diagnostics. The LEDs flash a specific sequence according to the diagnosis. See table 2.

TABLE 2

DS2 Green	DS1 Red	Condition
OFF	OFF	Power problem
Simultaneous Slow Flash		Normal operation
Alternating Slow Flash		5-min. anti-short cycle delay
OFF	Slow Flash	Low Pressure Fault
OFF	ON	Low Pressure Lockout
Slow Flash	OFF	High Pressure Fault
ON	OFF	High Pressure Lockout

18-Fan Control Board A191 (KHB)

Fan control board A191 (figure 9) provides indoor blower and outdoor fan control for all KHB units. For indoor blower control, the A191 can provide predefined two speed level output for different running mode if a belt drive blower with inverter is applicable. The A191 can provide 0 to 10 Volt output so that airflow can be adjusted for different running mode if an EBM blower is application. For outdoor fan control, the A191 can provide four-speed level PWM output for different running mode and low ambient condition. A191 has on-board dip switch setting to configure the unit size. The A191 provides minimum damper position operation for economizer. The A191 includes LVC2 functionality.

TABLE 3
Fan Control Board Diagnostic LED

Mode of Operation	LED
Normal Operation	Blink at 1 second rate
Power to board but a problem exists	Dim and no blink
Board Failure / No Power	Off

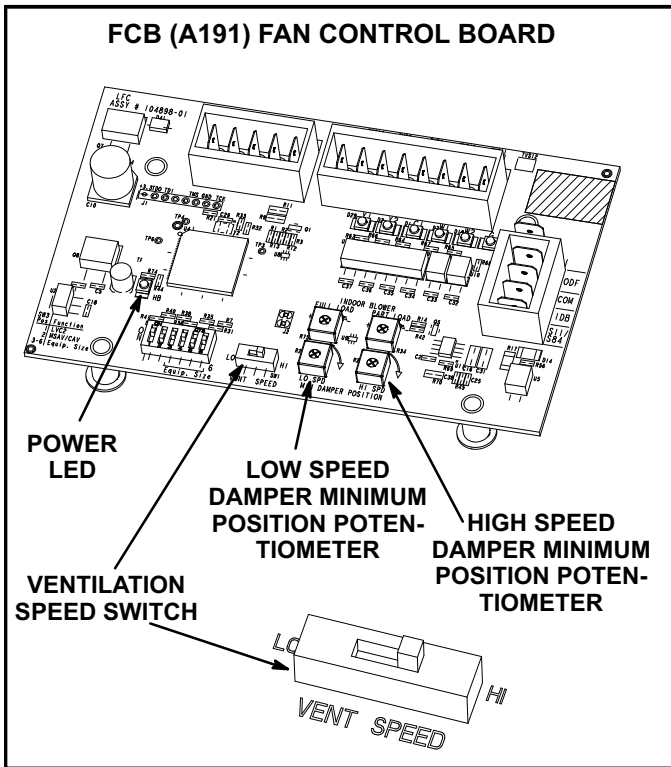

FIGURE 9

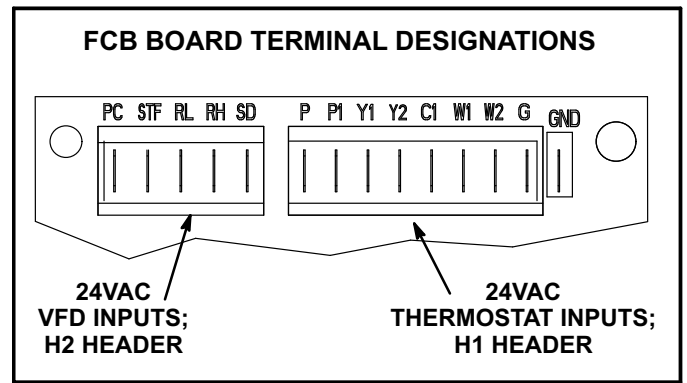

FIGURE 10

KHB Fan Control Board Run Test

DIP Switch Setup Check-Out Procedure

The unit configuration can be setup with the dip switch. See figure 11. There are two ways to approve dip switch set-up— by checking OD fan PWM signal and by checking OD fan speed (RPM) combined with ID blower speed checking. Either way should indicate the dip switch settings. See tables 4, 5 and NO TAG.

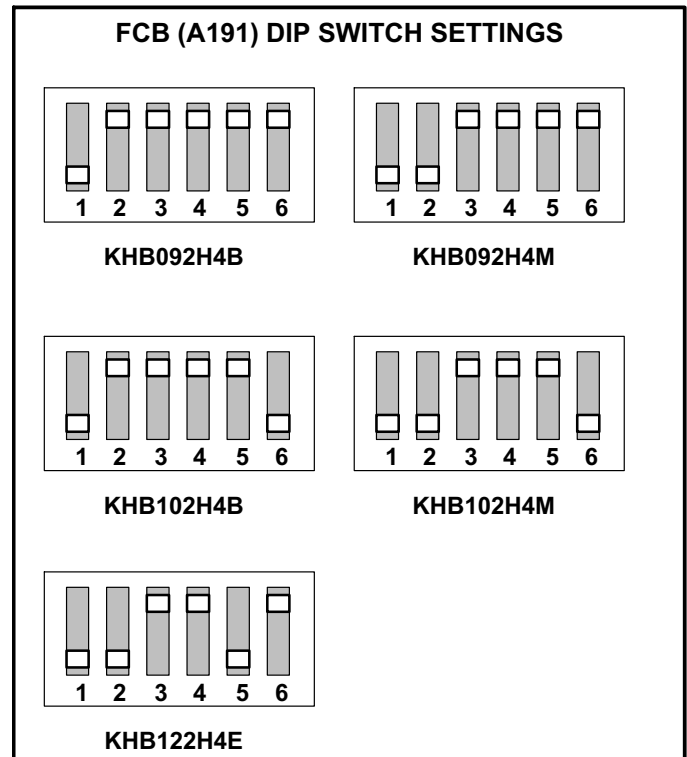

FIGURE 11

TABLE 4

Output Terminals	Voltage	ID Blower Operation
RL-SD	1VDC	Low Speed
RH-SD	24VDC	
RL-SD	24VDC	High Speed
RH-SD	1VDC	

Note - 24V is a reference number. It may vary from 18V to 24V.

**TABLE 5
OD Fan PWM Signal / ID Blower Speed**

Unit Configuration	OD Fan PWM Full Load	OD Fan PWM Part Load	ID Blower Out Put Full Load*	ID Blower Output Part Load*
KHB092 CAV	75%	40%	High Speed	High Speed
KHB092 MSAV w Inverter	75%	40%	High Sped	Low Speed
KHB102 CAV	80%	50%	High Speed	High Speed
KHB102 MSAV w Inverter	80%	50%	High Speed	Low Speed
KHB122 MSAV w EBM	75%	40%	6.33 Volt (default)	4.7 Volt (default)

*ID blower output with inverter. Measure the IDB output--6.33 Volt for full load by default, 4.7 Volt for part load by default. ID blower voltage output may change depending on the potentiometer setting.

19- VFD Phase Protection Monitor (A42)

A42 is an optional 3-phase line monitor that protects against phase loss, phase reverse and phase unbalance. The unit will not start if phase is incorrect. and will shut down if proper phasing is interrupted.

20- Terminal Block TB13

TB13 provides power connection for KHA/KHB units with belt drive blowers driven by inverter and KHB units with direct drive blowers.

PLUMBING COMPONENTS
KHA/KHB092, KHA/KHB102 and KHA120

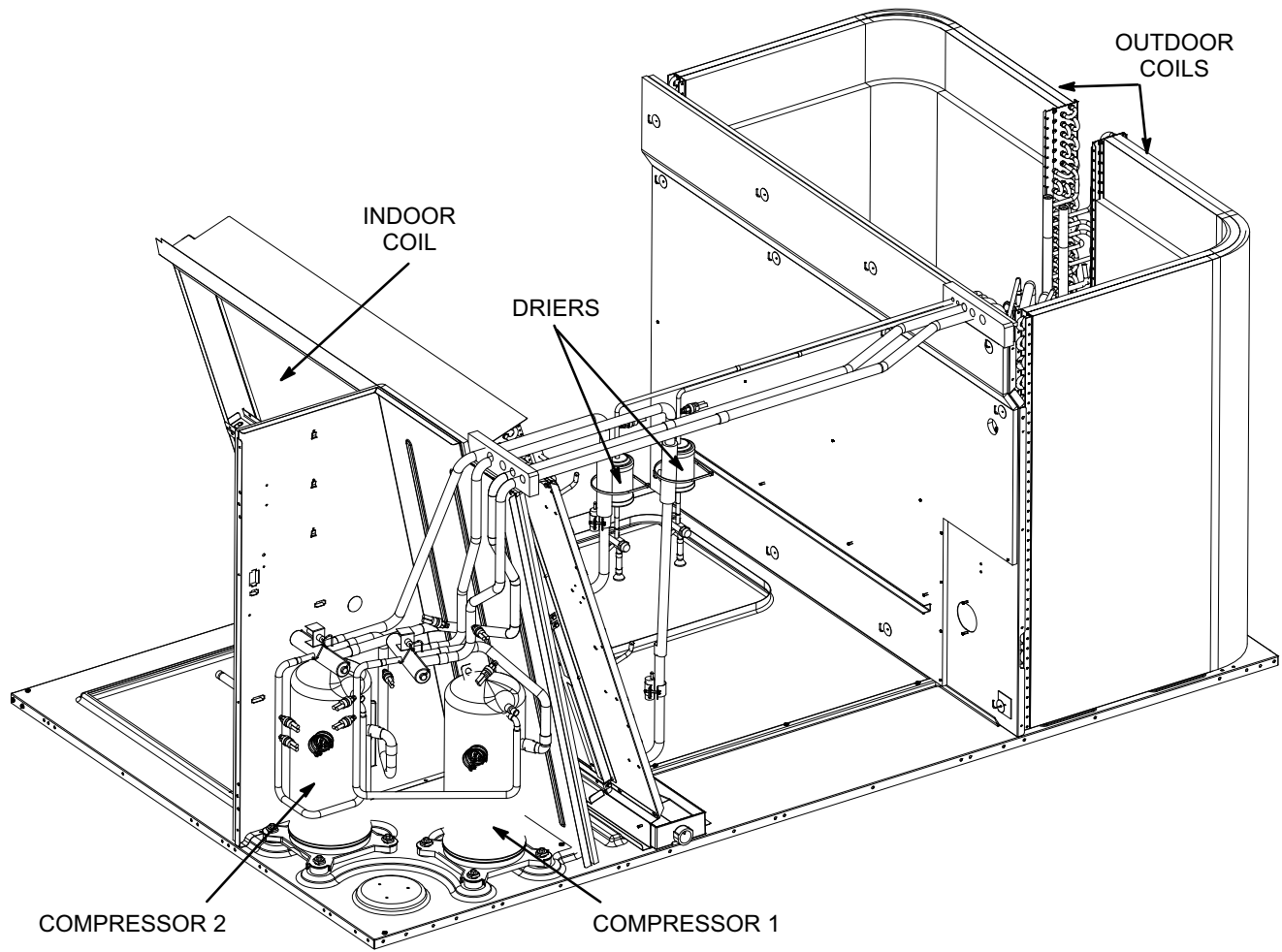

COMPRESSOR DETAIL
front view

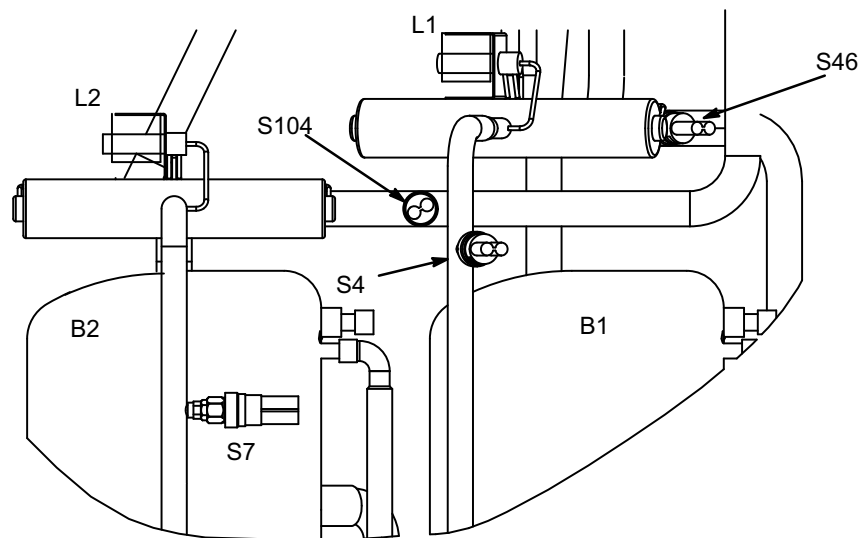
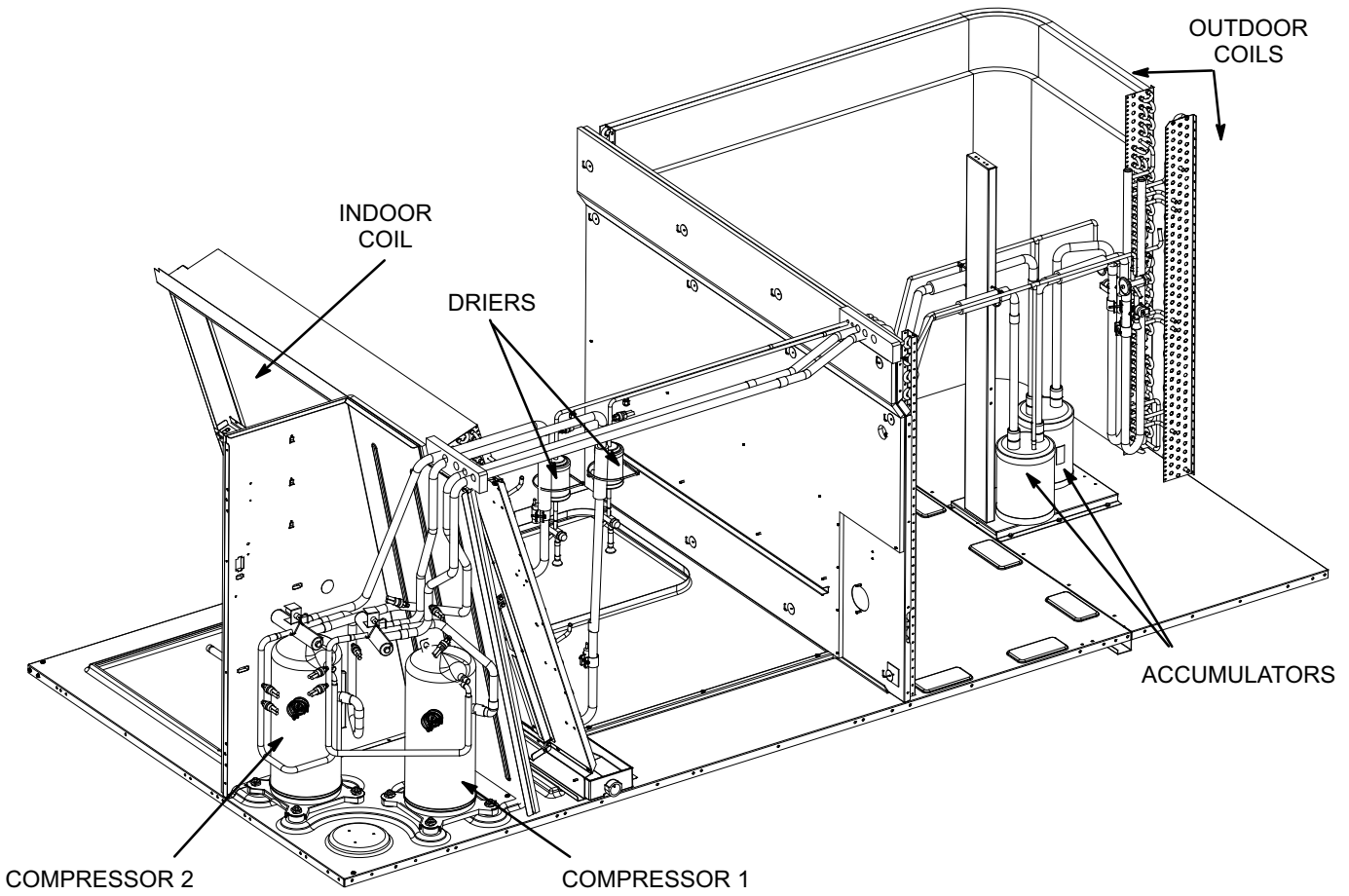

FIGURE 12

PLUMBING COMPONENTS KHA150 and KHB122



COMPRESSOR DETAIL front view

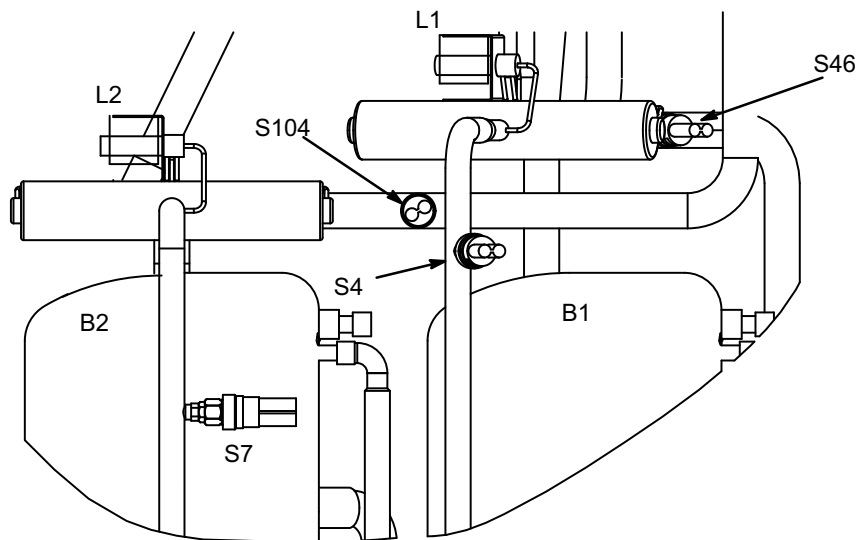

FIGURE 13

B-Cooling Components

KHA/KHB units use independent cooling circuits consisting of separate compressors, outdoor coils and indoor coil (with 2 separate stages). See figure 12 for 092, 102, and 120 units and figure 13 for 122 and 150. Units are equipped with two draw-through type condenser fans. All 092, 102, 120 and 150 units are equipped with belt-drive blowers and KHB122 is equipped with direct-drive blower which draw air across the indoor coil during unit operation.

Cooling may be supplemented by a factory- or field-installed economizer. The indoor coils are slab type and are stacked. Each indoor coil uses a thermostatic expansion valve as the primary expansion device. Each indoor coil is also equipped with enhanced fins and rifled tubing. In all units each compressor is protected by a freeze-stat (on each indoor coil) and a high pressure switch (S4, S7). Low ambient switches (S11, S84) are available as an option for additional compressor protection. Low ambient switch (S185) is available as an option for KHB units only.

1-Compressors B1 and B2

All KHA/KHB092/150 units use two scroll compressors. All compressors are equipped with independent cooling circuits. Compressor capacity may vary from stage to stage. In all cases, the capacity of each compressor is added to reach the total capacity of the unit. See "SPECIFICATIONS" and "ELECTRICAL DATA" (table of contents) or compressor nameplate for compressor specifications.

⚠ WARNING

Electrical shock hazard. Compressor must be grounded. Do not operate without protective cover over terminals. Disconnect power before removing protective cover. Discharge capacitors before servicing unit. Failure to follow these precautions could cause electrical shock resulting in injury or death.

Each compressor is energized by a corresponding compressor contactor.

NOTE-Refer to the wiring diagram section for specific unit operation.

⚠ IMPORTANT

Some scroll compressors have an internal vacuum protector that will unload scrolls when suction pressure goes below 20 psig. A hissing sound will be heard when the compressor is running unloaded. Protector will reset when low pressure in system rises above 40 psig. DO NOT REPLACE COMPRESSOR.

2-Freeze-stats S49 and S50

Each unit is equipped with a low temperature switch (freeze-stat) located on the return bend of each indoor coil. S49 (first circuit) and S50 (second circuit) are located on the corresponding indoor coils.

Each freeze-stat is a SPST N.C. auto-reset switch which opens at $29^{\circ}\text{F} \pm 3^{\circ}\text{F}$ ($-1.7^{\circ}\text{C} \pm 1.7^{\circ}\text{C}$) on a temperature drop and closes at $58^{\circ}\text{F} \pm 4^{\circ}\text{F}$ ($14.4^{\circ}\text{C} \pm 2.2^{\circ}\text{C}$) on a temperature rise. To prevent coil icing, freeze-stats open during compressor operation to temporarily disable the respective compressor until the coil warms sufficiently to melt any accumulated frost.

If the freeze-stats are tripping frequently due to coil icing, check the unit charge, airflow and filters before allowing unit back in operation. Make sure to eliminate conditions which might promote indoor coil ice buildup.

3-High Pressure Switches S4 and S7

The high pressure switches is a manual reset SPST N.C. switch which opens on a pressure rise. The switch is located in the compressor discharge line and is wired in series with the compressor contactor coil.

S4 (first circuit) and S7 (second circuit) are wired in series with the respective compressor contactor coils.

When discharge pressure rises to 640 ± 10 psig (4412 ± 69 kPa) (indicating a problem in the system) the switch opens and the respective compressor is de-energized (the economizer can continue to operate).

4-Low Ambient Switches S11, S84 & S185 (optional)

The low ambient switch is an auto-reset SPST N.O. pressure switch which allows for mechanical cooling operation at low outdoor temperatures. In all models a switch is located in each liquid line prior to the indoor coil section.

In the KHA/KHB092/150, S11 and S84 wired in parallel are wired in series with outdoor fan relay K10.

When liquid pressure rises to 450 ± 10 psig (3102 ± 69 kPa), the switch closes and the condenser fans are energized. When liquid pressure on both refrigerant circuit drops to 240 ± 10 psig (1655 ± 69 kPa), the switch opens and the condenser fans are de-energized. This intermittent fan operation results in higher evaporating temperature allowing the system to operate without icing the indoor coil and losing capacity.

In the KHB units, an extra low ambient switch S185 is wired in series with outdoor fan relay K10 at stage 1 liquid line. When liquid pressure at stage 1 rises to 300 ± 10 psig (2068 ± 69 kPa), switch closes. When liquid pressure on stage 1 drops to 180 ± 10 psig (1241 ± 69 kPa), the switch opens. When liquid line pressure drops below 240 ± 10 psig (1655 ± 69 kPa) but above 180 ± 10 psig (1241 ± 69 kPa), a low ambient control (A191) energizes the condenser fans run at 25% PWM. This allows the condenser fans to run at steady state to help reduce condenser fan cycling and improve the fan motor as well as system operating reliability. If condenser fan air temperature keeps dropping to certain level, and liquid line pressure drops below 180 ± 10 psig (1241 ± 69 kPa), the condenser fans will de-energize. When liquid line pressure rises to 300 ± 10

psig (2068 +/- 69 kPa) , the condenser fans will energize to 25% PWM. Once the pressure switch resets at 450 +/-10 psig (3102 +/-69 kPa) the condenser fans resume back to normal operation.

5-Reversing Valve L1 and L2

A refrigerant reversing valve with a 24 volt solenoid coil is used to reverse refrigerant flow during unit operation in all KHA/KHB units. The reversing valve is connected in the vapor line of the refrigerant circuit. The reversing valve coil is energized during cooling demand and during defrost.

Reversing valve L1 and L2 are controlled by the defrost control board CMC1 in response to cooling demand or by defrost.

6-Defrost Pressure Switch S46 and S104

The defrost pressure switch S46 and S104 are auto-reset SPST N.C. pressure switches which open on a pressure rise. All KHA/KHB units are equipped with these switches. The switches are located on the discharge line. S46 and S104 are wired in series with the CMC1 control board.

When discharge pressure reaches 450 ± 10 psig (3102 ± 69 kPa) in either circuit (indicating defrost is completed) the appropriate switch opens. The switches automatically reset when pressure in the suction line drops to 300 ± 20 psig (2068 ± 138 kPa).

7-Defrost Temperature Switch S6 and S9

Defrost thermostat switches S6 and S9 have S.P.S.T. N.O. contacts which close on a temperature fall (initiating defrost). The switches are located on the expansion valve distributor assembly at the inlet to the outdoor coil. The switch monitors the outdoor coil suction temperature to determine when defrost is needed. When the outdoor coil suction temperature falls to $35^{\circ}\text{F} \pm 4^{\circ}\text{F}$ ($1.7^{\circ}\text{C} \pm 2.2^{\circ}\text{C}$) the switch closes (initiating defrost after minimum run time of 30, 60, or 90 minutes). When the temperature rises to $60^{\circ}\text{F} \pm 5^{\circ}\text{F}$ ($15.6^{\circ}\text{C} \pm 2.8^{\circ}\text{C}$) the switch opens.

8-Filter Drier (all units)

KHA/KHB units have a filter drier located in the liquid line of each refrigerant circuit at the exit of each condenser coil (outdoor coil in KHA/KHB units). The drier removes contaminants and moisture from the system.

9-Condenser Fan Motors B4 and B5

See specifications section of this manual for specifications of condenser fans B4 and B5. All KHA motors are ball bearing type single-phase motors. All KHB motors are electrical commutated condenser fan motors (ECM). The ECM motors are wired directly to 230VAC power but do not operate until a pulse width modulated (PWM) control signal is sent from A191 fan control board. There are four predefined PWM output signal with different running mode and low

ambient condition. All condenser fans should run at the same speed if the indicated PWM signal is issued. The fans may be removed for servicing and cleaning by removing the fan grilles.

C-Blower Compartment

The blower compartment in all KHA/KHB092/150 units is located between the indoor coil and the outdoor coil section. The blower assembly is accessed by disconnecting the blower motor and all other plugs and removing the screws in front of the blower housing. The blower pulls out as shown in figures 14 and 15.

1-Blower Wheels

All KHA092/150 and KHB092/102 units have one 15 in. x 15 in. (381 mm x 381 mm) blower wheel. KHB122 units have direct drive blower assembly with backward inclined blower wheel.

2-Indoor Blower Motor B3

All KHA and KHB092/102 units use three-phase single-speed belt-drive blower motors. The KHB122 model uses three-phase variable speed direct drive blower motors. CFM adjustments are made by adjusting the motor pulley (sheave) for single speed blower motors. Motors are equipped with sealed ball bearings. All motor specifications are listed in the SPECIFICATIONS (table of contents) in the front of this manual. Units may be equipped with motors manufactured by various manufacturers, therefore electrical FLA and LRA specifications will vary. See unit name plate for information specific to your unit.

OPERATION / ADJUSTMENT

Belt-Driven Supply Air Inverter Units - Units are equipped with a phase monitor located in the control compartment. The phase monitor will detect the phasing of incoming power. If the incoming power is out of phase or if any of the three phases are lost, the indicating LED on the phase monitor will turn red and the unit will not start. In normal operation with correct incoming power phasing, the LED will be green.

Blower Operation

Initiate blower demand at thermostat according to instructions provided with thermostat. Unit will cycle on thermostat demand. The following steps apply to applications using a typical electro-mechanical thermostat.

- 1- Blower operation is manually set at the thermostat sub-base fan switch. With fan switch in **ON** position, blowers will operate continuously.
- 2- With fan switch in **AUTO** position, the blowers will cycle with demand. Blowers and entire unit will be off when system switch is in **OFF** position.

Blower Access

The blower assembly is secured to a sliding base which allows the entire assembly to be pulled out of the unit. See figure 14 for belt drive assembly and figure 15 for direct drive assembly. Follow the steps below.

- 1- *On belt drive blowers* - Loosen the reusable wire tie which secures the blower wiring to the blower motor mounting plate.
On direct drive blowers - Loosen the reusable wire tie which secures the controls and high voltage blower wiring to the blower housing.
- 2- Remove and retain screws on either side of sliding frame. Pull frame toward outside of unit.

- 3- Slide frame back into original position when finished servicing. Reattach the blower wiring in the previous location on the blower motor base using the wire tie..
- 4- Replace retained screws on either side of the sliding frame.

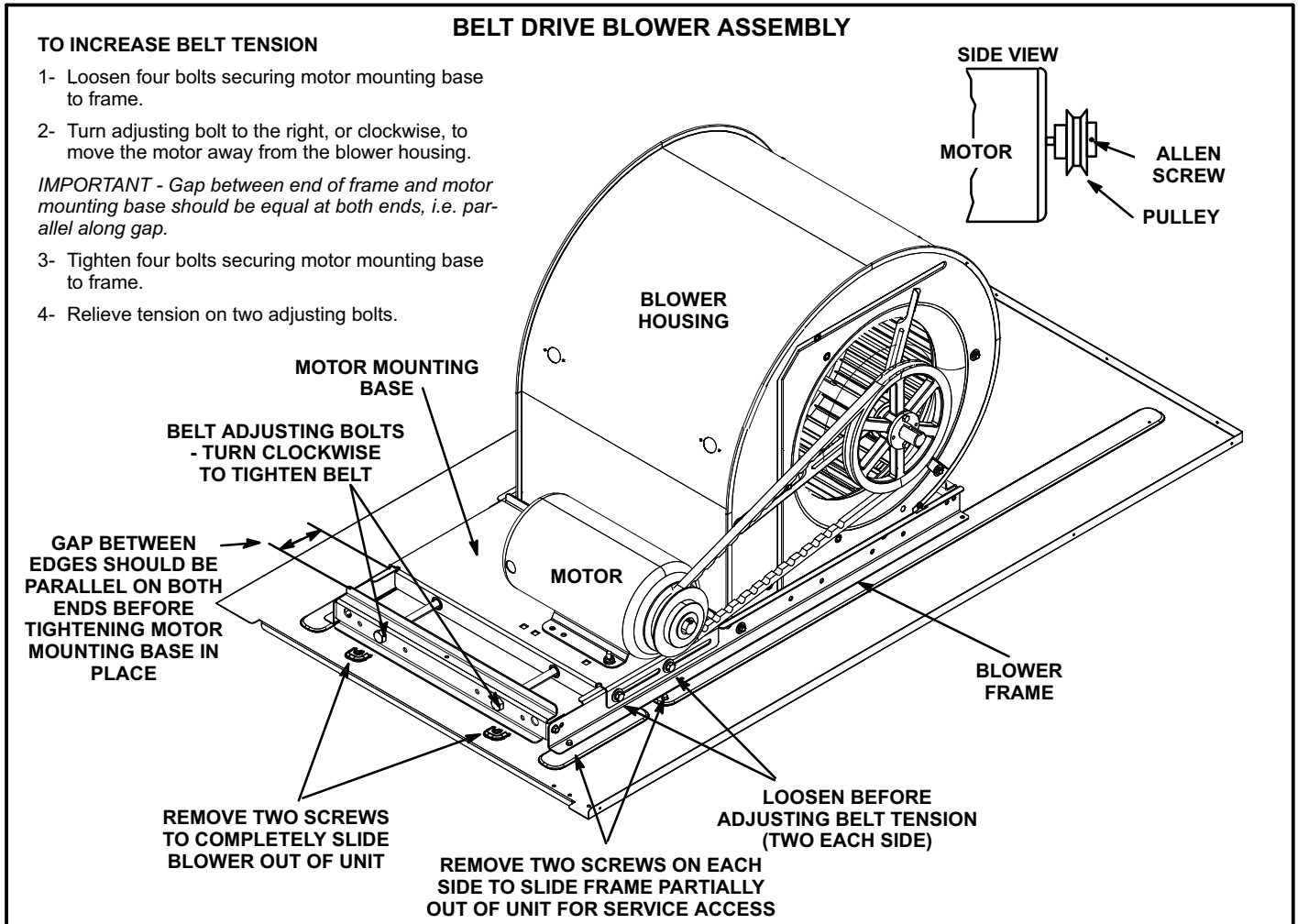

FIGURE 14

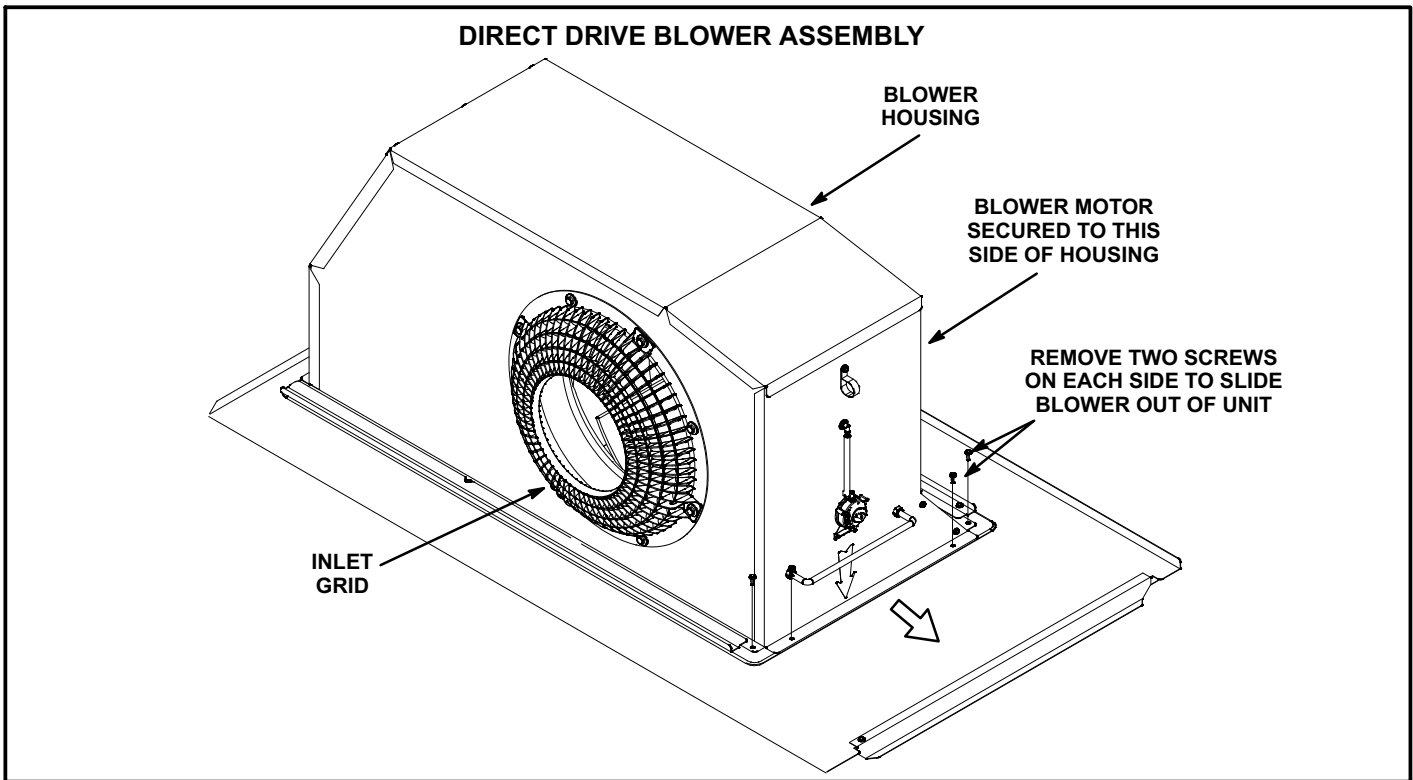

FIGURE 15

Determining Unit CFM

IMPORTANT - Belt-driven supply air inverter units are factory-set to run the blower at full speed when there is a blower (G) demand without a heating or cooling demand. Use the following procedure to adjust motor pulley to deliver the full load cooling or heating CFM. See *Belt-Drive Inverter Start-Up* in this section to set blower CFM for all modes once the motor pulley is set.

IMPORTANT - Direct drive variable blower unit CFM is determined by the Fan Control board. See *Direct Drive Variable Speed Start-Up* section.

- 1- The following measurements must be made with a dry indoor coil. Run blower without a cooling demand. Measure the indoor blower shaft RPM. Air filters must be in place when measurements are taken.
- 2- With all access panels in place, measure static pressure external to unit (from supply to return).
- 3- Refer to blower tables in BLOWER DATA (table of contents) in the front of this manual. Use static pressure and RPM readings to determine unit air volume.
- 4- The blower RPM can be adjusted at the motor pulley. Loosen Allen screw and turn adjustable pulley clockwise to increase CFM. Turn counterclockwise to decrease CFM. See figure 14. Do not exceed minimum and maximum number of pulley turns as shown in table 6.

TABLE 6
MINIMUM AND MAXIMUM PULLEY ADJUSTMENT

Belt	Minimum Turns Open	Maximum Turns Open
A Section	No minimum	5
B Section	1*	6

*No minimum number of turns open when B belt is used on pulleys 6" O.D. or larger.

Blower Belt Adjustment

Maximum life and wear can be obtained from belts only if proper pulley alignment and belt tension are maintained. Tension new belts after a 24-48 hour period of operation. This will allow belt to stretch and seat grooves. Make sure blower and motor pulley are aligned as shown in figure 16.

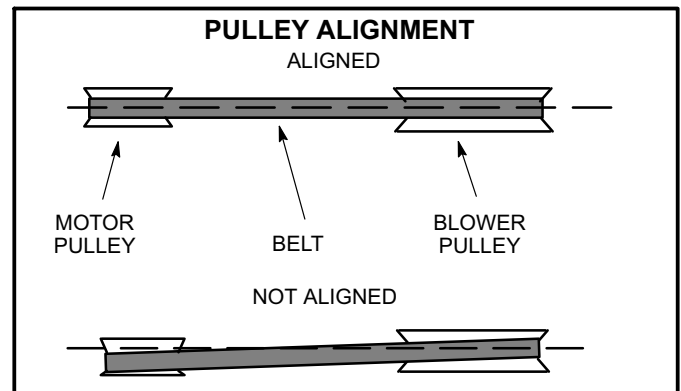

FIGURE 16

- 1- Loosen four bolts securing motor base to mounting frame. See figure 14.

2- To increase belt tension -

Turn adjusting bolt to the right, or clockwise, to move the motor outward and tighten the belt. This increases the distance between the blower motor and the blower housing.

To loosen belt tension -

Turn the adjusting bolt to the left, or counterclockwise to loosen belt tension.

3- Tighten two bolts on motor pulley side.

IMPORTANT - Align top edges of blower motor base and mounting frame base parallel before tightening two bolts on the other side of base. Motor shaft and blower shaft must be parallel.

4- Tighten two bolts on other side of base.

Check Belt Tension

Overtensioned belts shortens belt and bearing life. Check belt tension as follows:

- 1- Measure span length X. See figure 17.
- 2- Apply perpendicular force to center of span (X) with enough pressure to deflect belt 1/64" for every inch of span length or 1.5mm per 100mm of span length.

Example: Deflection distance of a 40" span would be 40/64" or 5/8".

Example: Deflection distance of a 400mm span would be 6mm.

- 3- Measure belt deflection force. For a used belt, the deflection force should be 5 lbs. (35kPa). A new belt deflection force should be 7 lbs. (48kPa).

A force below these values indicates an undertensioned belt. A force above these values indicates an overtensioned belt.

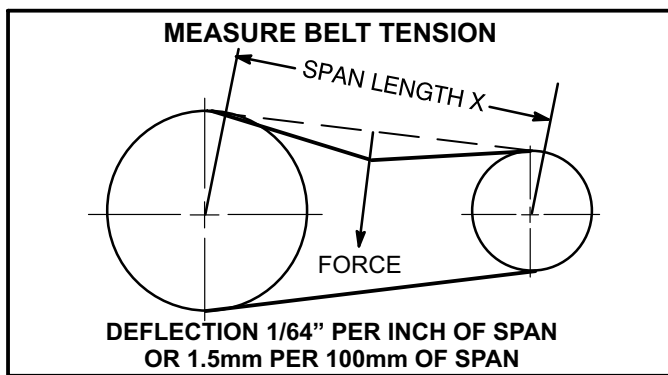

FIGURE 17

Belt Drive Inverter Start-Up

A-General

1. Units are available with an optional inverter which provides two blower speeds. The blower will operate at lower speeds when cooling demand is low and higher speeds when cooling demand is high. This results in lower energy consumption.

2. Units will operate at high speed during ventilation (blower "G" only signal) but can be adjusted to operate at low speed.

3. Low speed is approximately 2/3 of the full speed RPM.

B-Set Maximum Blower CFM

1. Initiate a blower (G) only signal from the room thermostat or control system.
2. Adjust the blower pulley to deliver the full (high speed) CFM in the typical manner. See *Determining Unit CFM* in the Blower Operation and Adjustment section.

C-Set Blower Speed During Ventilation

To save energy during ventilation, the blower speed can be set to low. This is accomplished by changing the ventilation speed switch on the VFD (figure 18) or FCB (Figure 19) control board to "LO".

Note - On units equipped with an economizer, set damper minimum position as shown in the next section. After adjusting the low speed minimum position, the ventilation speed switch will be in the "LO" position.

D-Set Damper Minimum Position (Units W/ Economizer)

To maintain required minimum ventilation air volumes when the unit is in the occupied mode, two minimum damper positions must be set. A high and a low speed potentiometer are provided on the VFD or FCB control board to adjust minimum damper position. See figure 18 and 19.

Set High Speed Minimum Position

1. Initiate a blower (G) only AND occupied demand from the room thermostat or control system.
2. Set the ventilation speed switch on the VFD or FCB control board to "HI".
3. Rotate the high speed potentiometer on the VFD or FCB control board to set the high speed minimum damper position.
4. Measure the intake air CFM. If the CFM is lower than the design specified CFM for ventilation air, use the potentiometer to increase the damper percent open. If the CFM is higher than specified, decrease the damper percent open.

Note - Intake air CFM can also be determined using the outdoor air temperature, return air temperature and mixed air temperature. Refer to the economizer or outdoor air damper installation instructions.

Set Low Speed Minimum Position

1. Initiate a blower (G) only AND occupied demand from the room thermostat or control system.
2. Set the ventilation speed switch on the VFD or FCB control board to "LO".
3. Rotate the low speed potentiometer on the VFD or FCB control board to set the low speed minimum damper position.

4. Measure the intake air CFM. If the CFM is lower than the design specified CFM for ventilation air, use the potentiometer to increase the damper percent open. If the CFM is higher than specified, decrease the damper percent open.

Note - Intake air CFM can also be determined using the outdoor air temperature, return air temperature and mixed air temperature. Refer to the economizer or outdoor air damper installation instructions.

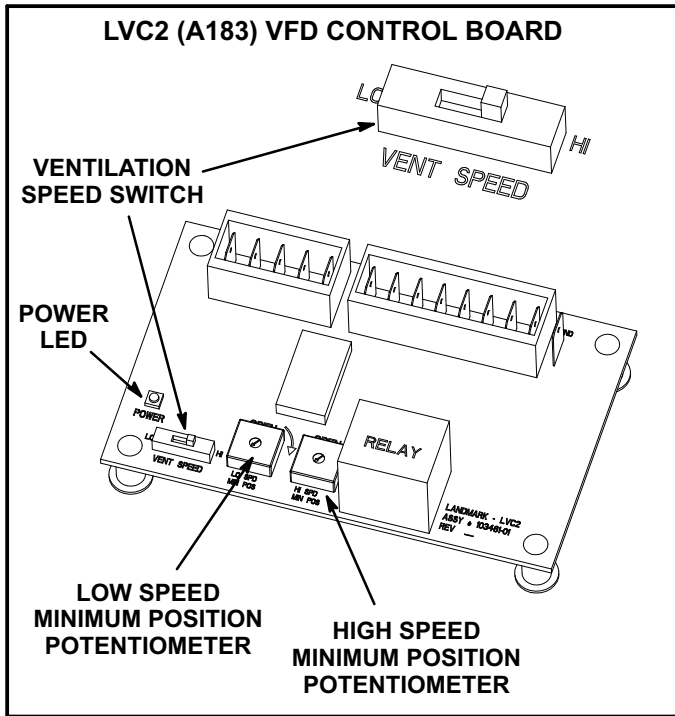

FIGURE 18

Direct Drive Variable Speed Inverter Start-Up

A-General

Units are available with an optional direct drive blower which can be set at high and low speed. The blower will operate at lower speeds when demand is low and higher speeds when demand is high. This results in lower energy consumption.

1. Initiate a blower (G) only signal from the room thermostat or control system. The blower will operate in high speed.
2. Measure the blower RPM and static pressure and use appropriate blower table to calculate supply air CFM. See *Determining Unit CFM* in the Blower Operation and Adjustment section.
3. If the resulting CFM is lower than the desired CFM, rotate the fan control board high speed potentiometer clockwise (or counterclockwise if CFM is too high).
4. Calculate the CFM and adjust potentiometer as needed to meet desired CFM

5. Initiate a blower (G) AND first-stage (Y1) cooling signal from the room thermostat or control system. The blower will operate in low speed.
6. Calculate the low speed CFM in the same manner as the high speed CFM.
7. Adjust low speed potentiometer as needed to meet desired CFM.

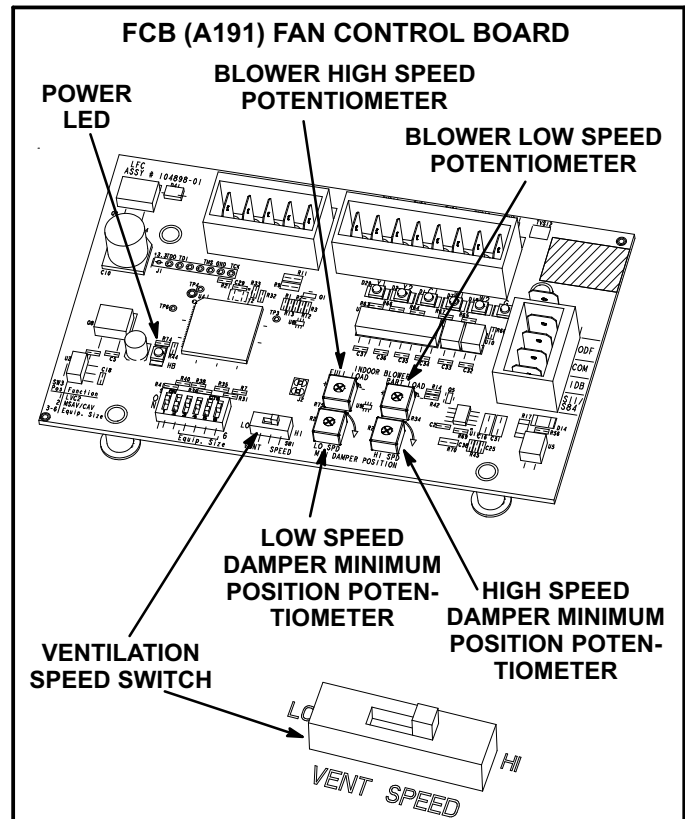

FIGURE 19

C-Set Blower Speed During Ventilation

To save energy during ventilation, the blower speed can be set to low. This is accomplished by changing the ventilation speed switch on the FCB control board to "LO". See figure 19.

Note - On units equipped with an economizer, set damper minimum position as shown in the next section. After adjusting the low speed minimum position, the ventilation speed switch will be in the "LO" position.

D-Set Damper Minimum Position (Units W/ Economizer)

To maintain required minimum ventilation air volumes when the unit is in the occupied mode, two minimum damper positions must be set. A high and a low speed potentiometer are provided on the FCB control board to adjust minimum damper position. See figure 19.

Set High Speed Minimum Position

1. Initiate a blower (G) only AND occupied demand from the room thermostat or control system.
2. Set the ventilation speed switch on the FCB control board to "HI".

3. Rotate the high speed potentiometer on the FCB control board to set the high speed minimum damper position.
4. Measure the intake air CFM. If the CFM is lower than the design specified CFM for ventilation air, use the potentiometer to increase the damper percent open. If the CFM is higher than specified, decrease the damper percent open.

Note - Intake air CFM can also be determined using the outdoor air temperature, return air temperature and mixed air temperature. Refer to the economizer or outdoor air damper installation instructions.

Set Low Speed Minimum Position

1. Initiate a blower (G) only AND occupied demand from the room thermostat or control system.
2. Set the ventilation speed switch on the FCB control board to "LO".
3. Rotate the low speed potentiometer on the FCB control board to set the low speed minimum damper position.
4. Measure the intake air CFM. If the CFM is lower than the design specified CFM for ventilation air, use the potentiometer to increase the damper percent open. If the CFM is higher than specified, decrease the damper percent open.

Note - Intake air CFM can also be determined using the outdoor air temperature, return air temperature and mixed air temperature. Refer to the economizer or outdoor air damper installation instructions.

Troubleshoot FCB Board (A191)

Refer to wiring diagram sections B (unit), C (control) and D (economizer) located on inside of unit panels.

1. Inspect the board for damaged components. Replace the board if damaged components are found.
2. Check all wire connections to board; secure if loose.
3. Check for 24VAC signal at the thermostat blower input (G to GND terminal). See figure 20.

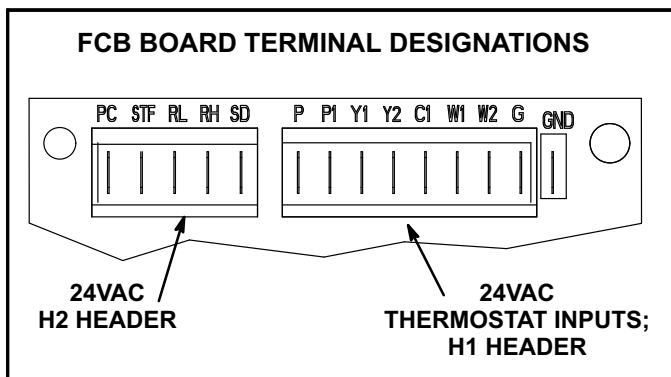

FIGURE 20

4. If there is no thermostat signal, troubleshoot back toward the thermostat.
5. Check the power LED on the board. See figure 19.

6. The LED should be blinking at a 1-second rate when operating normally. If the LED is dim and not blinking, this indicates power is provided but a problem exists with the board.
7. If the power LED is not on, check voltage between FCB terminals PC (H2-1) and SD (H2-5). Voltage should read 24VAC.
8. If voltage does not read 24VAC, disconnect the H2 header from the FCB terminal block (to make sure the FCB is not shorting 24VAC supply from terminal strip TB1). Measure the voltage between the end terminals on the H2 header. If 24VAC is present, replace the FCB board.

Troubleshoot LVC2 Board (A183)

Refer to wiring diagram sections B (unit), C (control) and D (economizer) located on inside of unit panels.

1. Inspect the LVC2 for damaged components. Replace the LVC2 if damaged components are found.
2. Check all wire connections to LVC2; secure if loose.
3. Check for 24VAC signal at the thermostat blower input (G to GND terminal). See figure 21.

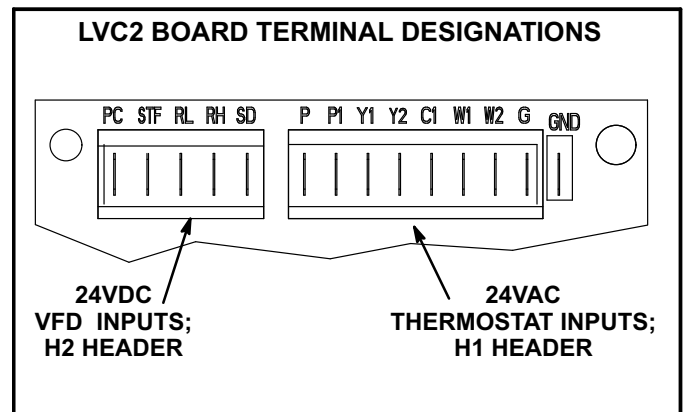

FIGURE 21

4. If there is no thermostat signal, troubleshoot back toward the thermostat.
5. Check the power LED on the board. See figure 18.
6. If the power LED is not on, check voltage between LVC2 terminals PC (H2-1) and SD (H2-5). Voltage should read 24VDC.
7. If voltage does not read 24VDC, disconnect the H2 header from the LVC2 VFD inputs terminal block (to make sure the LVC2 is not shorting 24VDC supply from the inverter). Measure the voltage between the end terminals on the H2 header. If 24VDC is present, replace the LVC2 board. If no voltage is read, troubleshoot the VFD.
8. When LVC2 24VAC thermostat blower (G) input and 24VDC power are present, check the LVC2 low and high speed outputs. The LVC2 uses inverse logic to enable the blower; 1VDC will be read at the enabled blower speed terminal. See table 7.
9. If all inputs are correct and the unit still does not operate as intended, replace LVC2 board.

**TABLE 7
LVC2 BOARD BLOWER OUTPUTS**

Output Terminals	Voltage	Blower Operation
RL-SD	1VDC	Low Speed
RH-SD	24VDC	
RL-SD	24VDC	High Speed
RH-SD	1VDC	
RL-SD	1VDC	Illegal State (replace board)
RH-SD	1VDC	
RL-SD	24VDC	Blower Off (replace board)
RH-SD	24VDC	

D-Optional Electric Heat Components

Table 8 shows electric heat fuse ratings. See Options/Accessories section (see table of contents) for KHA/KHB to EHO match-ups. See Electrical/Electric Heat Data section (see table of contents) of this manual for electrical ratings and capacities.

All electric heat sections consist of electric heating elements exposed directly to the air stream. See figure 23. EHO parts arrangement is shown in figures 23 and 24. Multiple-stage elements are sequenced on and off in response to thermostat demand.

1-Contactors K15, K16

Contactors K15 and K16 are three-pole double-break contactors located on the electric heat vestibule. All contactors are equipped with a 24VAC coil. The coils in the K15 and K16 contactors are energized by a W2 thermostat demand, K9, and DL2. Contactor K15 energizes the first stage heating elements, while K16 energizes the second stage heating elements. On M-volt units, contactors are CE approved by manufacturer (Siemens). See figure 5.

2-High Temperature Limits S15 (Primary)

S15 is a SPST N.C. auto-reset thermostat located on the back panel of the electric heat section below the heating elements. S15 is the high temperature limit for the electric heat section. When S15 opens, indicating a problem in the system, contactor K15 is de-energized. When K15 is de-energized, first stage and all subsequent stages of heat are de-energized. For EHO102/150 units, the electric heat section thermostat is factory set to open at $170^{\circ}\text{F} \pm 5^{\circ}\text{F}$ ($76^{\circ}\text{C} \pm 2.8^{\circ}\text{C}$) on a temperature rise and automatically reset at $130^{\circ}\text{F} \pm 6^{\circ}\text{F}$ ($54.4^{\circ}\text{C} \pm 3.3^{\circ}\text{C}$) on a temperature fall. For EHO100 units, the electric heat section thermostat

is factory set to open at $160^{\circ}\text{F} \pm 5^{\circ}\text{F}$ ($71.0^{\circ}\text{C} \pm 2.8^{\circ}\text{C}$) on a temperature rise and automatically reset at $120^{\circ}\text{F} \pm 6^{\circ}\text{F}$ ($49.0^{\circ}\text{C} \pm 3.3^{\circ}\text{C}$) on a temperature fall. The thermostat is not adjustable.

3-High Temperature Limit S20, S157, S158, S15, S160 & S161 (Secondary)

Limits are SPST N.C. manual-reset thermostat. Like the primary temperature limit, S20 is wired in series with the first stage contactor coil (K15) and second stage contactor coil (K16). When S20 opens, contactors (K15, K16) are de-energized. When the contactors are de-energized, first stage and all subsequent stages of heat are de-energized. The thermostat is factory set to open at $220^{\circ}\text{F} \pm 6^{\circ}\text{F}$ ($104^{\circ}\text{C} \pm 3.3^{\circ}\text{C}$) on a temperature rise and can be manually reset when temperature falls below 160°F (71.0°C).

4-Terminal Strip TB2

Terminal strip TB2 is used for single point power installations only. TB2 distributes L1, L2 and L3 power to TB3. Units with multi-point power connections will not use TB2.

5-Terminal Strip TB3

Electric heat line voltage connections are made to terminal strip TB3 located in the upper left corner of the electric heat vestibule. TB3 distributes power to the electric heat components.

6-Heating Elements HE1 through HE6

Heating elements are composed of helix wound bare nichrome wire exposed directly to the air stream. Three elements are connected in a three-phase arrangement. The elements in 208/230V units are connected in a "Delta" arrangement. Elements in 460 and 575V units are connected in "Wye" arrangement. Each stage is energized independently by the corresponding contactors located on the electric heat vestibule panel. Once energized, heat transfer is instantaneous. High temperature protection is provided by primary and redundant high temperature limits and overcurrent protection is provided by fuses.

7-Fuse F3

Fuse F3 are housed in a fuse block which holds three fuses. Each F3 fuse is connected in series with each leg of electric heat. Figure 24 and table 8 show the fuses used with each electric heat section. For simplicity, the service manual labels the fuses F3 - 1 through F3 - 4.

8-Unit Fuse Block & Fuse F3 and F4

Three line voltage fuses F4 provide short circuit and ground fault protection to all cooling components in the KHA/KHB units with electric heat. The fuses are rated in accordance with the amperage of the cooling components.

TABLE 8

KHA/KHB ELECTRIC HEAT SECTION FUSE RATING					
EHO QUANTITY & SIZE	VOLTAGES	FUSE (3 each)			
		F3 - 1	F3 - 2	F4 - 1	F4 - 2
EHO075-1, 7.5	208/230V		25 Amp 250V	----	----
	460V		15 Amp 600V	----	----
	575V		10 Amp 600V	----	----
EHO150-1, 15	208/230V		50 Amp 250V	----	----
	460V		25 Amp 600V	----	----
	575V		20 Amp 600V	----	----
EHO225-1, 22.5	208/230V	50 Amp 250V	----	25 Amp 250V	----
	460V	25 Amp 600V	----	15 Amp 600V	----
	575V	20 Amp 600V	----	10 Amp 600V	----
EHO300-1, 30	208/230V	50 Amp 250V	----	50 Amp 250V	----
	460V	25 Amp 600V	----	25 Amp 600V	----
	575V	20 Amp 600V	----	20 Amp 600V	----
EHO450-1, 45	208/230V	50 Amp 250V	----	60 Amp 250V	60 Amp 250V
	460V	25 Amp 600V	----	50 Amp 600V	----
	575V	20 Amp 600V	----	40 Amp 600V	----
EHO600-1, 60	208/230V	60 Amp 250V	60 Amp 250V	60 Amp 250V	60 Amp 250V
	460V	50 Amp 600V	----	50 Amp 600V	----
	575V	40 Amp 600V	----	40 Amp 600V	----
EHO057-1, 5.7	384V	----	15 Amp 600V	----	----
EHO115-1, 15	384V	----	25 Amp 600V	----	----
EHO172-1, 17.2	384V	25 Amp 600V	----	15 Amp 600V	----
EHO230-1, 23.0	384V	25 Amp 600V	----	25 Amp 600V	----
EHO345-1, 34.5	384V	25 Amp 600V	----	40 Amp 600V	----
EHO459-1, 45.9	384V	40 Amp 600V	----	40 Amp 600V	----

ELECTRIC HEAT CONTROL ASSEMBLY

1-Electric Heat Relay K9

All KHA/KHB series units with electric heat use an electric heat relay K9. K9 is a N.O. DPDT pilot relay intended to electrically isolate the unit's 24V circuit from the electric heat 24V circuit. K9 is energized by CMC1. K9-1 closes, energizing timer DL2. K9 is located in the electric heat control assembly. See figure 22.

2-Time Delay DL2

DL2 is a factory-installed solid state timer used in 22.5 to 60 kW electric heat units. DL2 allows staging by providing a timed-interval between the first and second heating elements. When the timer is energized, the contacts are delayed for 30 seconds before closing. When the timer is de-energized, the contacts are delayed 1 second before opening. DL2 is located in the electric heat control assembly. See figure 22.

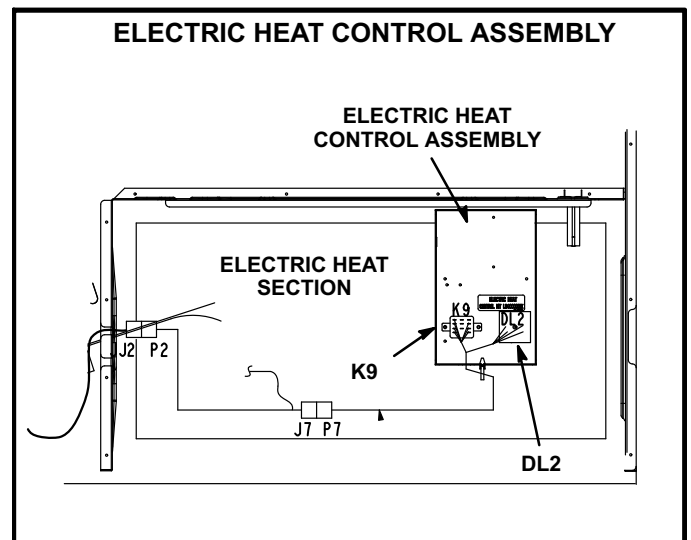

FIGURE 22

**EHO 7.5, 15, 22.5, 30, 45, 60KW
ELECTRIC HEAT SECTION PARTS ARRANGEMENT**

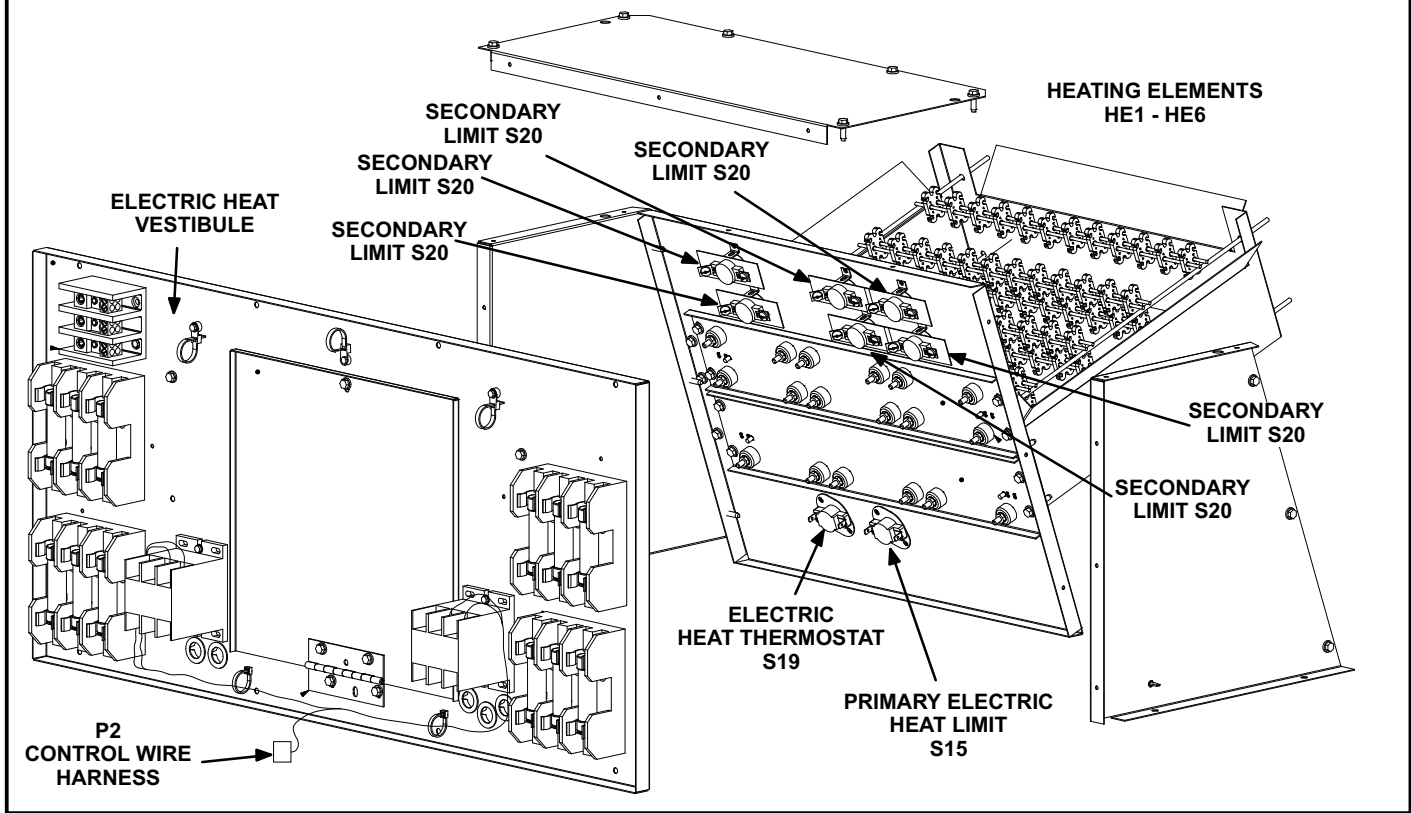

FIGURE 23

ELECTRIC HEAT VESTIBULE PARTS ARRANGEMENT

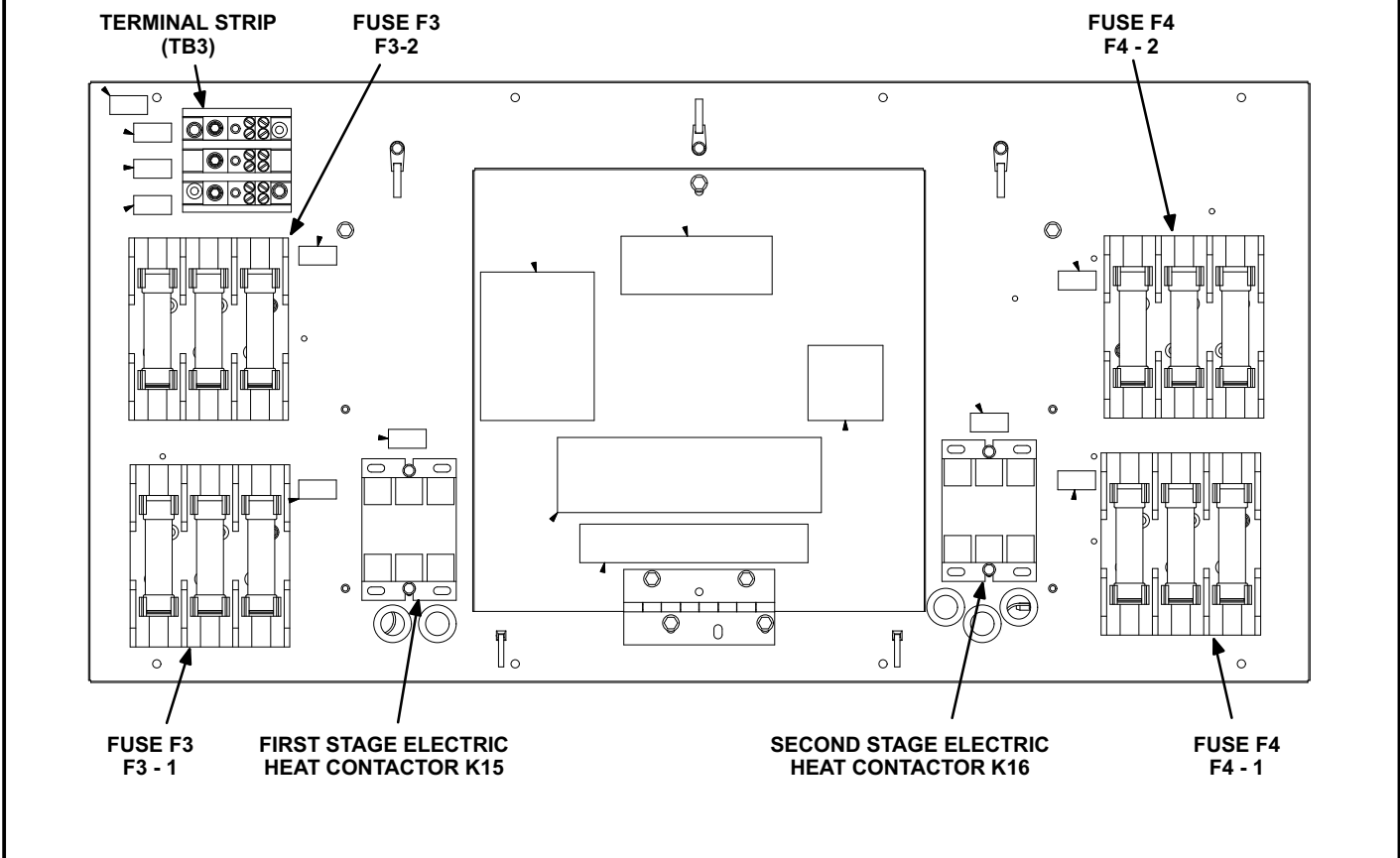

FIGURE 24

II-PLACEMENT AND INSTALLATION

Make sure the unit is installed in accordance with the installation instructions and all applicable codes. See accessories section for conditions requiring use of the optional roof mounting frame (LARMF).

III-START UP - OPERATION

Refer to startup directions and refer closely to the unit wiring diagram when servicing. See unit nameplate for minimum circuit ampacity and maximum fuse size.

A-Preliminary and Seasonal Checks

- 1- Make sure the unit is installed in accordance with the installation instructions and applicable codes.
- 2- Inspect all electrical wiring, both field and factory installed for loose connections. Tighten as required. Refer to unit diagram located on inside of unit control box cover.
- 3- Check to ensure that refrigerant lines are in good condition and do not rub against the cabinet or other refrigerant lines.
- 4- Check voltage at the disconnect switch. Voltage must be within the range listed on the nameplate. If not, consult the power company and have the voltage corrected before starting the unit.
- 5- Recheck voltage and amp draw with unit running. If voltage is not within range listed on unit nameplate, stop unit and consult power company. Refer to unit nameplate for maximum rated load amps.
- 6- Inspect and adjust blower belt (see section on Blower Compartment - Blower Belt Adjustment).

B-Heating Start Up

- 1- Set thermostat or temperature control device to initiate a first-stage heating demand.

A first-stage heating demand (W1) will energize compressors 1 and 2. Both outdoor fans are energized with a W1 demand.

Note - L1 and L2 reversing valves are de-energized in the heating mode.

KHA/KHB Units With Optional Electric Heat -

An increased heating demand (W2) will energize electric heat. Electric heat is also energized during the defrost cycle (W1) to maintain discharge air temperature.

C-Cooling Start Up

⚠ IMPORTANT

If unit is equipped with a crankcase heater. Make sure heater is energized 24 hours before unit start-up to prevent compressor damage as a result of slugging.

- 1- Set thermostat or temperature control device fan switch to **AUTO** or **ON**. Set thermostat or temperature control device to initiate a first-stage cooling demand. A first-stage Y1 cooling demand will energize L1 and L2 reversing valve solenoids and compressor 1. An increased cooling demand Y2 will initiate compressor 2.
Units With Optional Economizer -
The optional economizer will start on a first stage (Y1) cooling demand when outdoor air enthalpy is suitable. An increased cooling demand (Y2) with the economizer open will energize 1 compressor only.
- 2- Refrigerant circuits are factory charged with refrigerant. See unit rating plate for correct amount of charge.
- 3- Units contain two refrigerant circuits or systems. See figure 25 or 26.

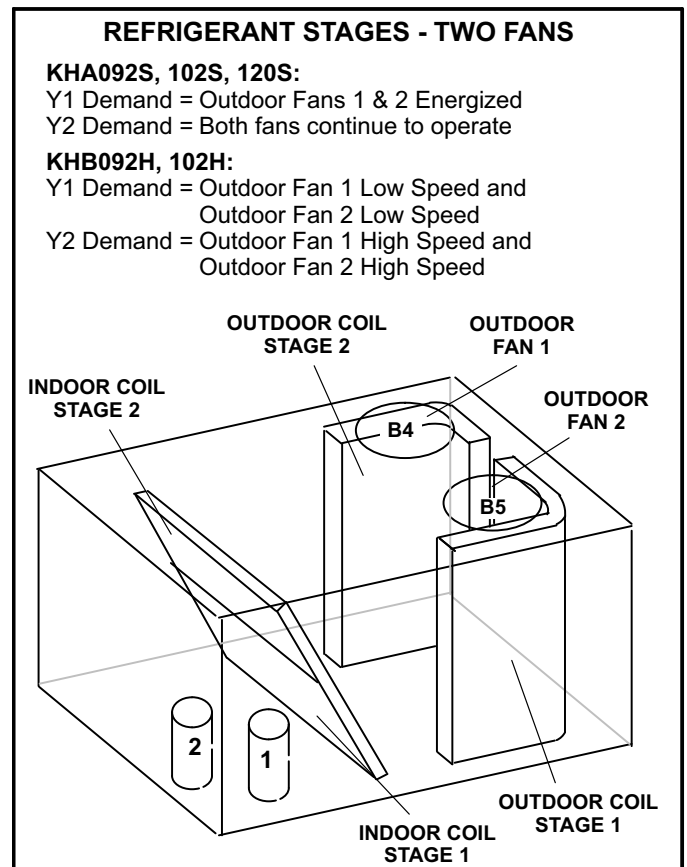

REFRIGERANT STAGES - THREE FANS

KHA150S:

Y1 Demand = Outdoor Fan 1, 2, & 3 Energized

Y2 Demand = All fans continue to operate

KHB122H:

Y1 Demand = Outdoor Fan 1 Low Speed and
Outdoor Fan 2 Low Speed and
Outdoor Fan 3 Low Speed

Y2 Demand = Outdoor Fan 1 High Speed and
Outdoor Fan 2 High Speed and
Outdoor Fan 3 High Speed

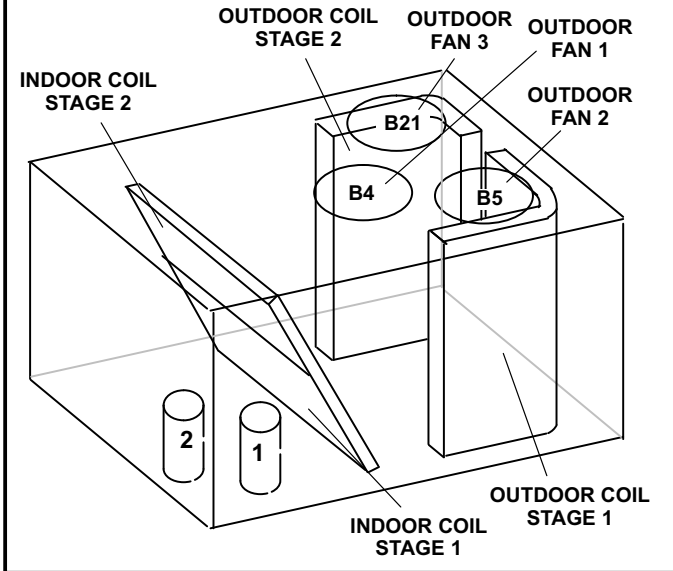

FIGURE 26

D-Safety or Emergency Shutdown

Turn off power to the unit. Close manual and main gas valves.

IV- SYSTEMS SERVICE CHECKS

⚠ WARNING

Refrigerant can be harmful if it is inhaled. Refrigerant must be used and recovered responsibly.

Failure to follow this warning may result in personal injury or death.

A-Charging

WARNING-Do not exceed nameplate charge under any condition. This unit is factory charged and should require no further adjustment. If the system requires additional refrigerant, reclaim the charge, evacuate the system, and add required nameplate charge.

NOTE - System charging is not recommended below 60° F (15° C). In temperatures below 60° F (15° C), the charge must be weighed into the system.

If weighing facilities are not available, or to check the charge, use the following procedure:

- 1- Attach gauge manifolds and operate unit in cooling mode with economizer disabled until system stabilizes (approximately five minutes).
- 2- Check each system separately with all stages operating.
- 3- Use a thermometer to accurately measure the outdoor ambient temperature.

- 4- Apply the outdoor temperature to tables 9 through 15 to determine normal operating pressures. Pressures are listed for sea level applications at 60°F dry bulb and 67°F wet bulb return air.
- 5- Compare the normal operating pressures to the pressures obtained from the gauges. Minor variations in these pressures may be expected due to differences in installations. Significant differences could mean that the system is not properly charged or that a problem exists with some component in the system. **Correct any system problems before proceeding.**
- 6- If discharge pressure is high, remove refrigerant from the system. If discharge pressure is low, add refrigerant to the system.
 - Add or remove charge in increments.
 - Allow the system to stabilize each time refrigerant is added or removed.
- 7- Use the following approach method along with the normal operating pressures to confirm readings.

TABLE 9

KHA092S NORMAL OPERATING PRESSURES

Outdoor Coil Entering Air Temp	CIRCUIT 1		CIRCUIT 2	
	Disch. ±10 psig	Suction ±5 psig	Disch. ±10 psig	Suction ±5 psig
65° F	253	139	252	139
75° F	291	141	290	140
85° F	333	144	332	143
95° F	378	146	377	145
105° F	428	149	428	149
115° F	483	153	483	151

TABLE 10

KHB092H NORMAL OPERATING PRESSURES

Outdoor Coil Entering Air Temp	CIRCUIT 1		CIRCUIT 2	
	Dis-charge ±10 psig	Suction ±5 psig	Dis-charge ±10 psig	Suction ±5 psig
65° F	250	140	257	142
75° F	287	143	295	145
85° F	329	146	336	147
95° F	371	148	382	150
105° F	423	151	435	153
115° F	472	154	486	156

TABLE 11

KHA102S NORMAL OPERATING PRESSURES

Outdoor Coil Entering Air Temp	CIRCUIT 1		CIRCUIT 2	
	Disch. ±10 psig	Suction ±5 psig	Disch. ±10 psig	Suction ±5 psig
65° F	258	132	258	135
75° F	299	136	299	138
85° F	340	140	340	143
95° F	388	144	387	147
105° F	439	149	439	150
115° F	490	154	494	153

**TABLE 12
KHB102H NORMAL OPERATING PRESSURES**

Outdoor Coil Entering Air Temp	CIRCUIT 1		CIRCUIT 2	
	Dis-charge ±10 psig	Suction ±5 psig	Dis-charge ±10 psig	Suction ±5 psig
65° F	257	136	261	139
75° F	296	139	298	142
85° F	335	141	339	144
95° F	384	144	390	147
105° F	431	147	441	149
115° F	485	150	495	152

**TABLE 13
KHA120S NORMAL OPERATING PRESSURES**

Outdoor Coil Entering Air Temp	CIRCUIT 1		CIRCUIT 2	
	Dis-charge ±10 psig	Suction ±5 psig	Dis-charge ±10 psig	Suction ±5 psig
65° F	261	128	264	131
75° F	299	131	303	131
85° F	342	134	346	135
95° F	387	137	393	138
105° F	436	140	444	144
115° F	489	143	497	147

**TABLE 14
KHB122H NORMAL OPERATING PRESSURES**

Outdoor Coil Entering Air Temp	CIRCUIT 1		CIRCUIT 2	
	Dis-charge ±10 psig	Suction ±5 psig	Dis-charge ±10 psig	Suction ±5 psig
65° F	248	131	251	134
75° F	284	134	287	136
85° F	322	136	329	139
95° F	371	139	381	142
105° F	416	142	429	144
115° F	470	145	488	148

**TABLE 15
KHA150S NORMAL OPERATING PRESSURES**

Outdoor Coil Entering Air Temp	CIRCUIT 1		CIRCUIT 2	
	Dis-charge ±10 psig	Suction ±5 psig	Dis-charge ±10 psig	Suction ±5 psig
65° F	245	130	250	131
75° F	284	134	289	135
85° F	326	137	330	137
95° F	371	140	374	140
105° F	419	144	420	143
115° F	470	147	469	145

B-Charging - Approach Method - AHRI Testing

- Using the same thermometer, compare liquid temperature to outdoor ambient temperature.

Approach Temperature = Liquid temperature (at condenser outlet) minus ambient temperature.

- Approach temperature should match values in table 16. An approach temperature greater than value shown indicates an undercharge. An approach temperature less than value shown indicates an overcharge.
- The approach method is not valid for grossly over or undercharged systems. Use tables 9 through 15 as a guide for typical operating pressures.

**TABLE 16
APPROACH TEMPERATURE**

Unit	Liquid Temp. Minus Ambient Temp.	
	1st Stage	2nd Stage
092S	10°F ± 1 (5.6°C ± 0.5)	10°F ± 1 (5.6°C ± 0.5)
092H 102S & H	8°F ± 1 (4.4°C ± 0.5)	9°F ± 1 (5.0°C ± 0.5)
120S	6°F ± 1 (3.3°C ± 0.5)	7°F ± 1 (3.9°C ± 0.5)
122H 150S	6°F ± 1 (3.3°C ± 0.5)	6°F ± 1 (3.3°C ± 0.5)

V-MAINTENANCE

The unit should be inspected once a year by a qualified service technician.

⚠ CAUTION
Electrical shock hazard. Turn off power to unit before performing any maintenance, cleaning or service operation on the unit.

⚠ CAUTION
Danger of sharp metallic edges. Can cause injury. Take care when servicing unit to avoid accidental contact with sharp edges.

A-Lubrication

All motors are lubricated at the factory. No further lubrication is required.

B-Filters

Units are equipped with four 18 X 24 X 2" filters. Filters should be checked and replaced when necessary with filters of like kind and size. Take note of air flow direction marking on filter frame when reinstalling filters. See figure 27.

NOTE-Filters must be U.L.C. certified or equivalent for use in Canada.

C-Supply Air Blower Wheel

Annually inspect supply air blower wheel for accumulated dirt or dust. Turn off power before attempting to remove access panel or to clean blower wheel.

D-Indoor Coil

Inspect and clean coil at beginning of each cooling and heating season. Clean using mild detergent or commercial coil cleanser. Flush coil and condensate drain with water taking care not to get insulation, filters and return air ducts wet.

E-Outdoor Coil

Clean outdoor coil annually with detergent or commercial coil cleaner and inspect monthly during the cooling season.

Outdoor coils are made of two formed slabs. Dirt and debris may become trapped between the slabs. To clean between slabs, carefully separate coil slabs (*no more than 4 inches*) and wash them thoroughly. See figure 28. Flush coils with water following cleaning.

F-Filter Drier

The unit is equipped with a biflow filter drier. If replacement is necessary, order another of like design.

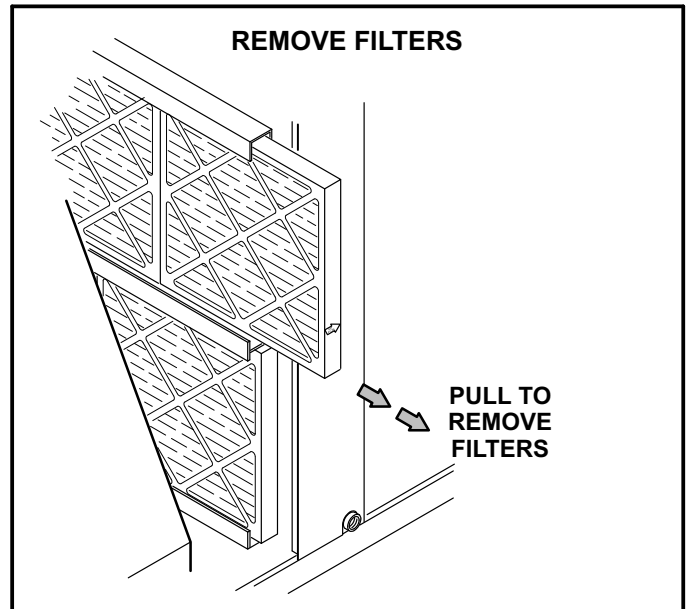

FIGURE 27

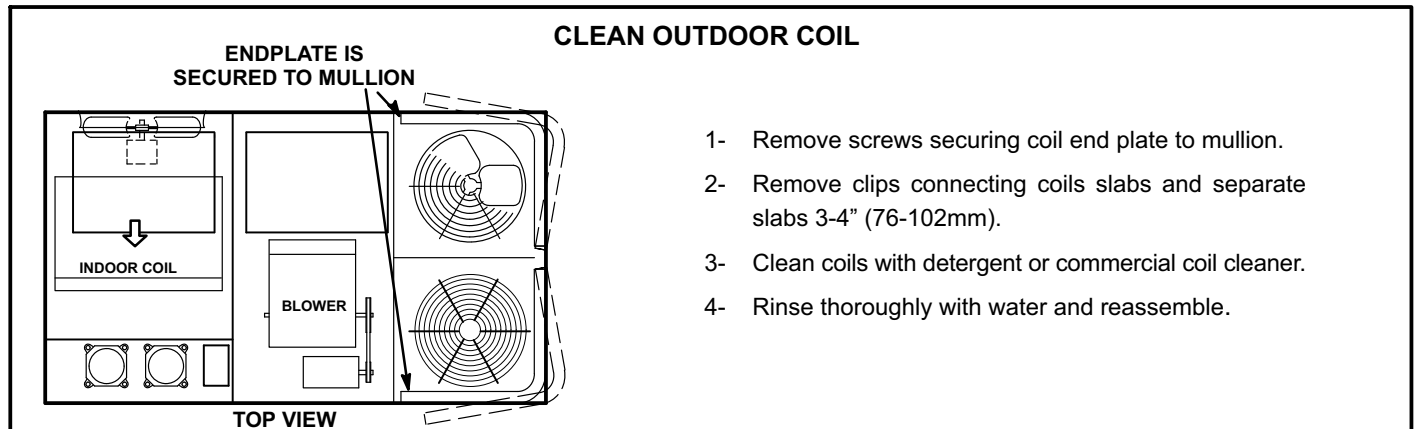

FIGURE 28

VI-ACCESSORIES

The accessories section describes the application of most of the optional accessories which can be factory or field installed to the KHA/KHB units. OPTIONAL ACCESSORIES section (see table of contents) show specific size per unit.

A-C1CURB Mounting Frames

When installing the KHA/KHB units on a combustible surface for downflow discharge applications, the C1CURB roof mounting frame is used. The roof mounting frames are available in heights from 8 to 24 inches and are recommended in all other applications but not required. If the KHA/KHB units are not mounted on a flat (roof) surface, they MUST be supported under all edges and under the middle of the unit to prevent sagging. The units MUST be mounted level within 1/16" per linear foot or 5mm per meter in any direction.

The assembled C1CURB mounting frame is shown in figure 29. Refer to the roof mounting frame installation instructions for details of proper assembly and mounting. The roof mounting frame MUST be squared to the roof and level before mounting. Plenum system MUST be installed before the unit is set on the mounting frame. Typical roof curbing and flashing is shown in figure 30. Refer to the roof mounting frame installation instructions for proper plenum construction and attachment.

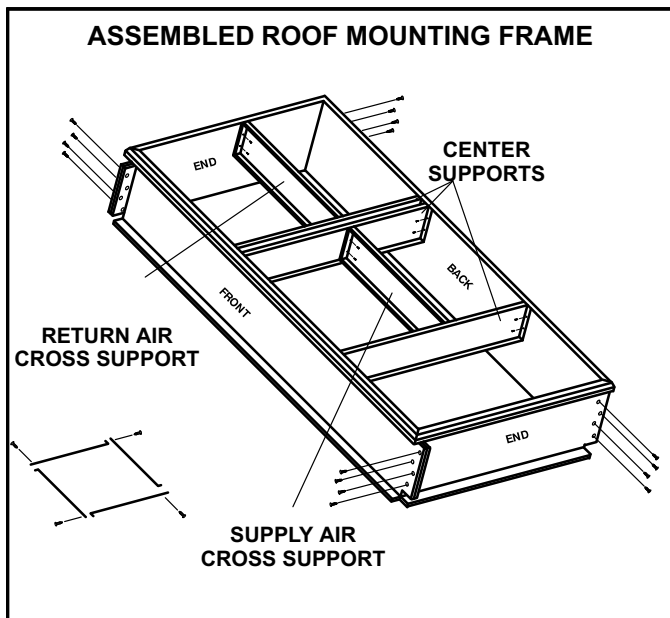

FIGURE 29

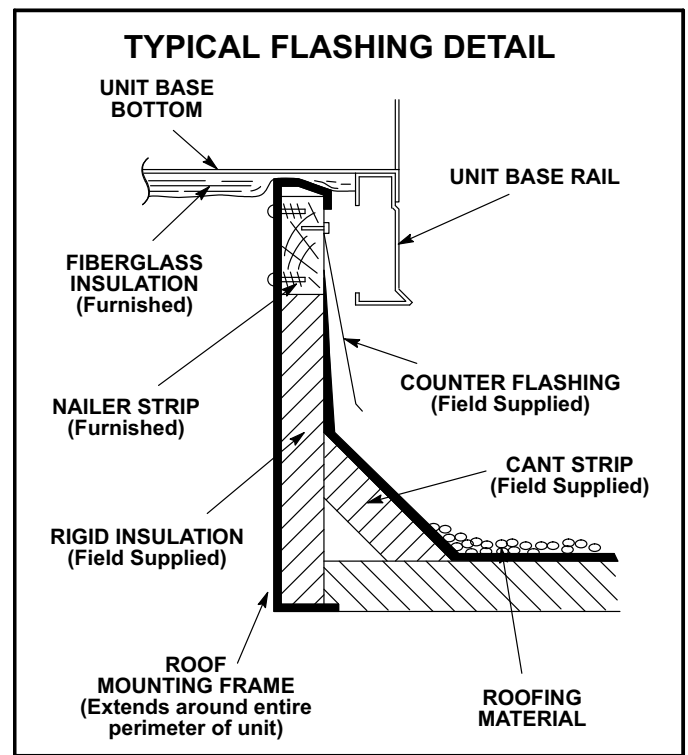

FIGURE 30

B-Transitions

Optional supply/return transition C1DIFF30B-1 is available for use with KHA/KHB 7.5-ton units. C1DIFF31B-1 is available for 8.5 and 10-ton units and C1DIFF32B-1 is available for use with KHA/KHB 12.5 ton units. All transitions are used with the appropriate C1CURB roof mounting frame. Transition must be installed in the mounting frame before installing the unit on the frame. Refer to the manufacturer's instructions included with the transition for detailed installation procedures.

C-Supply and Return Diffusers

Optional flush mount diffuser/return FD11 and extended mount diffuser/return RTD11 are available for use with the KHA/KHB units. Refer to manufacturer's instructions included with transition for detailed installation procedures.

D-C1DAMP Outdoor Air Dampers

Field- or Factory-Installed

Optional manual (C1DAMP10B-1) and motorized (C1DAMP20B-1) outdoor air dampers provide up to 25 percent fresh air for return. Motorized damper opens to minimum position simultaneously with the blower during the occupied period and remains closed during the unoccupied period. Manual damper assembly is manually operated; damper position is manually set at installation and remains in that position.

C1DAMP20B-1 MOTORIZED OUTDOOR AIR DAMPER

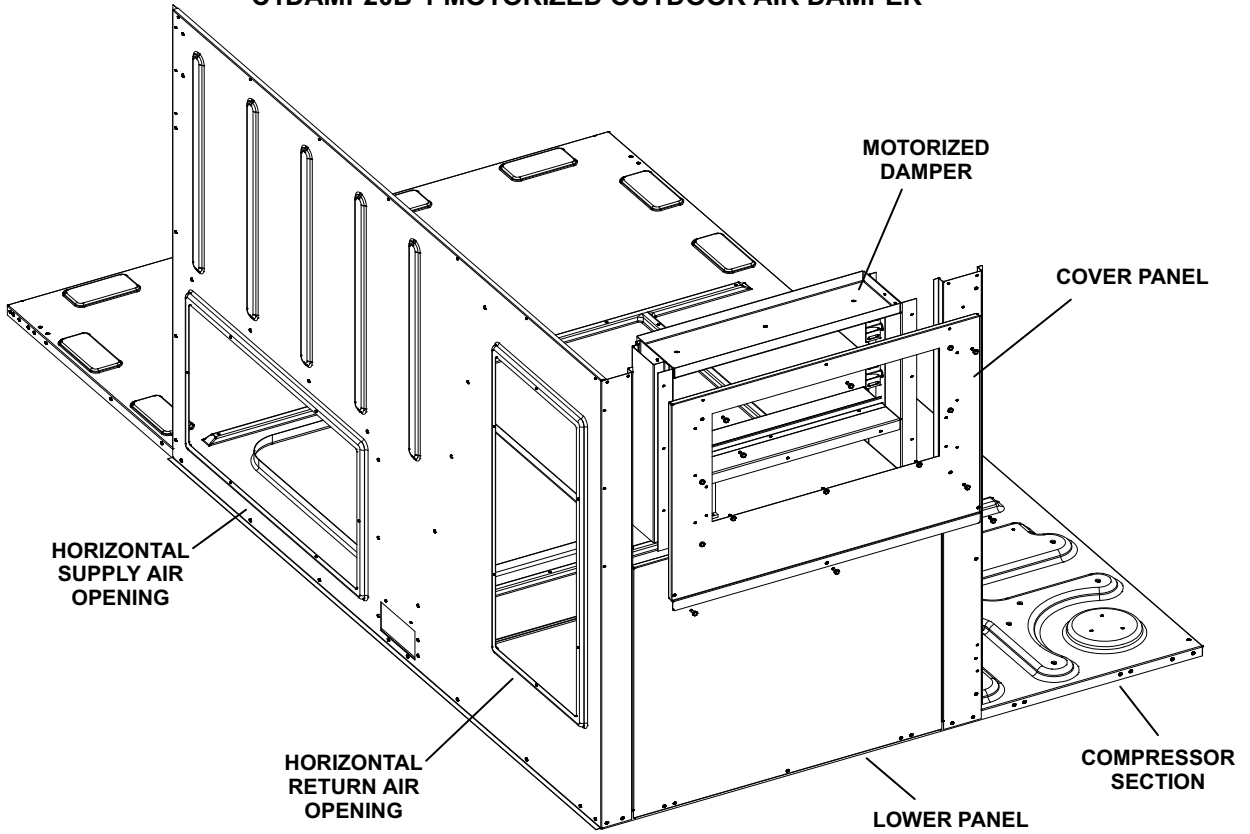

C1DAMP10B-1 MANUAL OUTDOOR AIR DAMPER

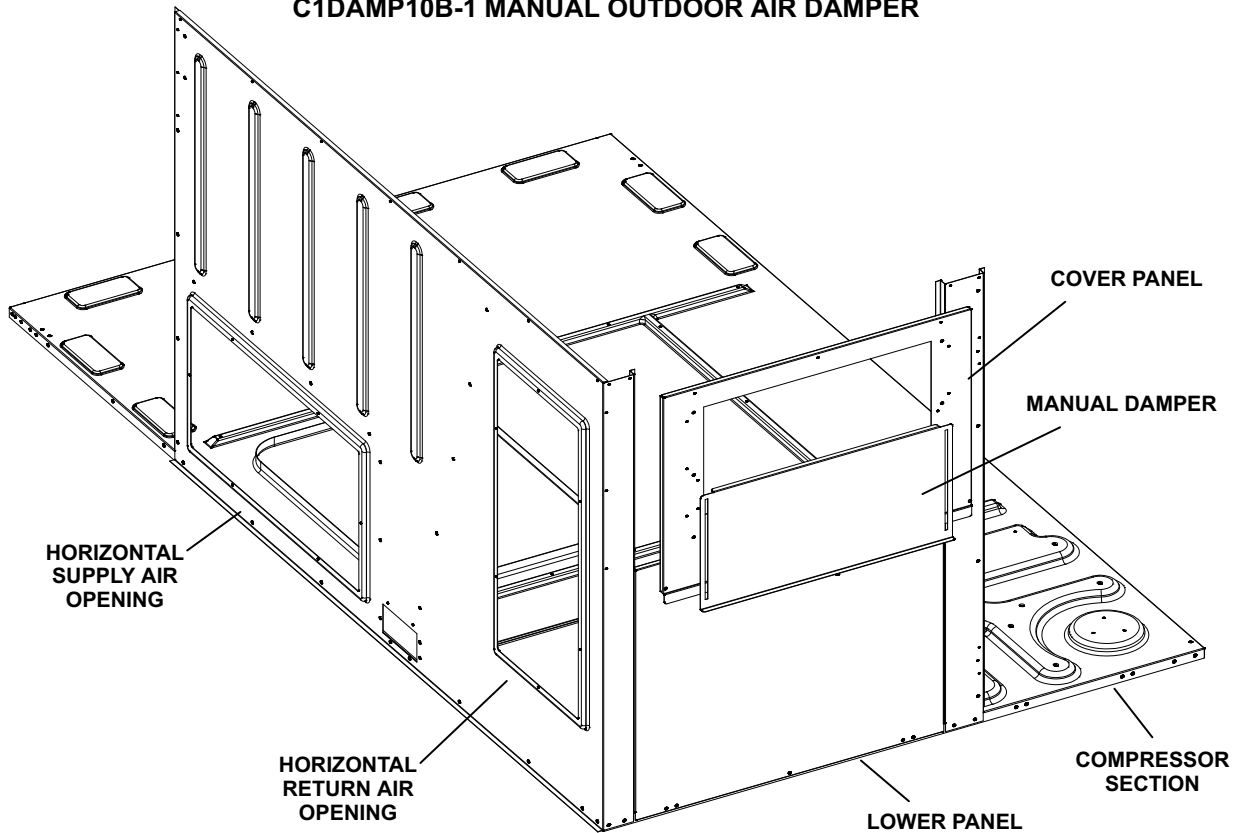

FIGURE 31

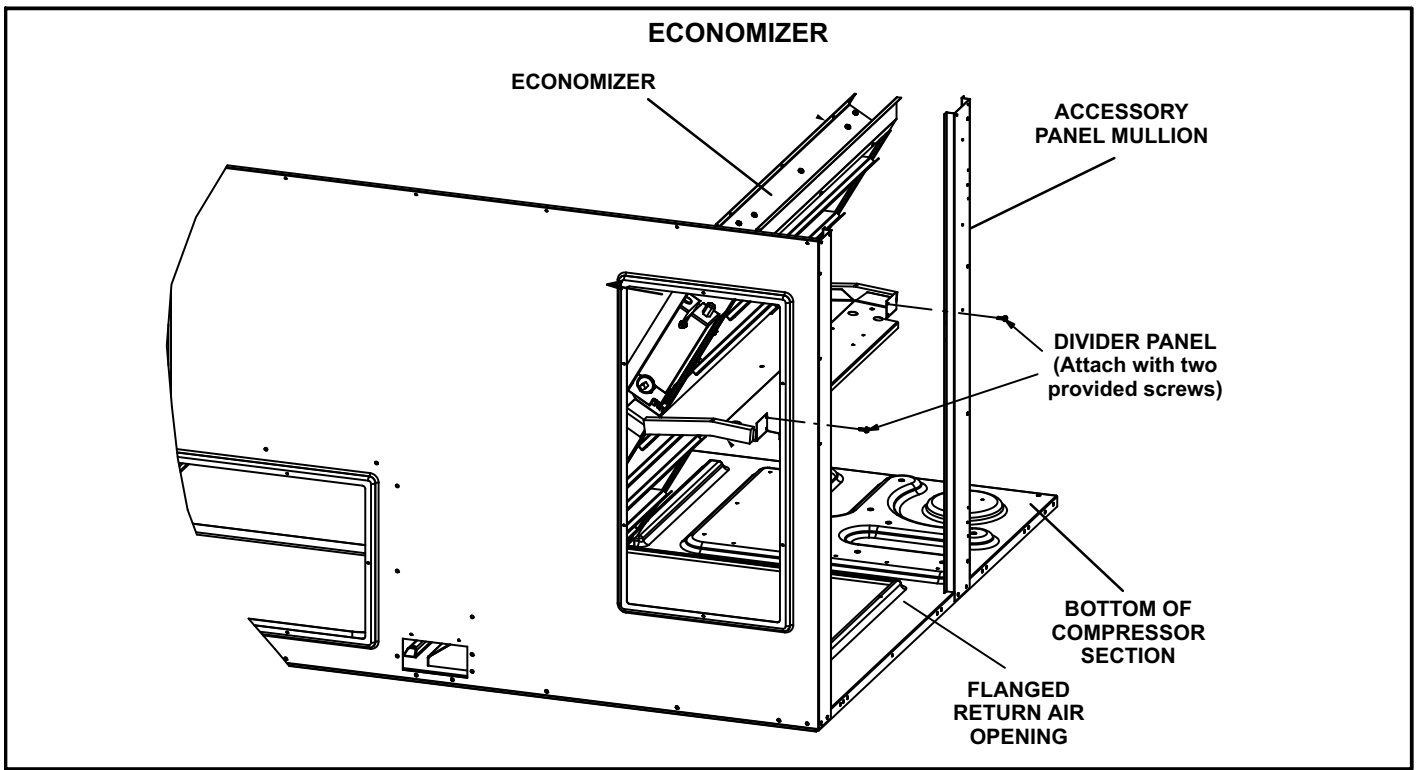

FIGURE 32

E-K1ECON20B Economizer
(Field- or Factory-Installed)

Economizers use outdoor air for free cooling when temperature and/or humidity is suitable. See figure 32.

The mixed air temperature sensor (R1) measures the supply air sensible temperature. See figure 33. The outdoor air sensible control is the default economizer control. An outdoor air single sensible sensor, S175, is also provided. See table 17 for outdoor and return air (OA and RA) sensor options. Refer to instructions provided with sensors for installation.

An IAQ sensor is used when demand control ventilation (DCV) is specified. Damper minimum position can be set lower than traditional minimum air requirements resulting in cost savings. The IAQ sensor allows the A6 to open dampers to traditional ventilation requirements as room occupancy (CO₂) increases.

TABLE 17

Sensors	Dampers will modulate to 55°F discharge air (RT6) when:
Single OA Sensible	OA temperature (S175) is lower than free cooling setpoint.
Single OA Sensible	OA temperature and humidity (A7) is lower than free cooling setpoint.
Differential Enthalpy - 1 in OA and 1 in RA	OA temperature and humidity (A7) is lower than RA temperature and humidity (A62).
IAQ Sensor	CO ₂ sensed (A63) is higher than CO ₂ setpoint.

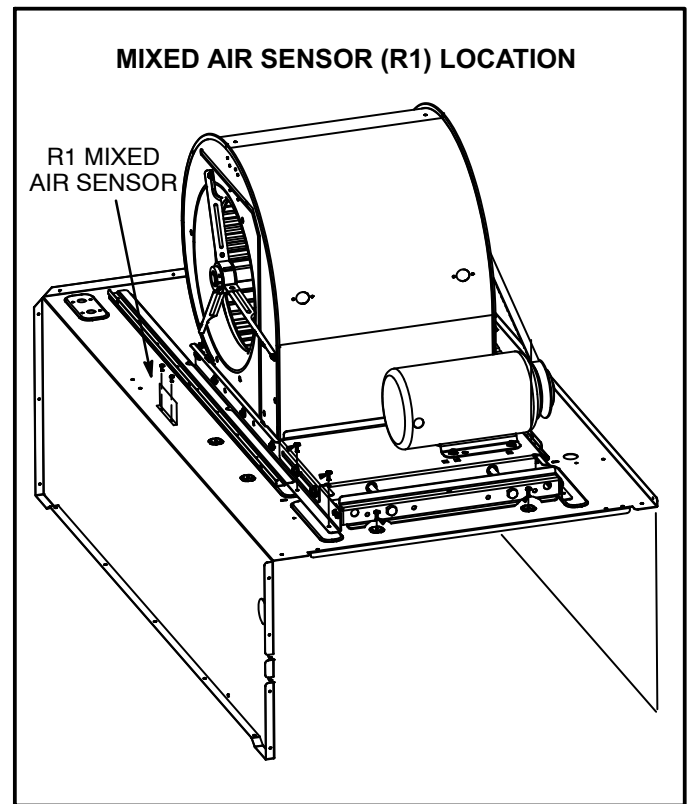

FIGURE 33

A6 Enthalpy Control LED'S

A steady green Free Cool LED indicates that outdoor air is suitable for free cooling.

When an optional IAQ sensor is installed, a steady green DCV LED indicates that the IAQ reading is higher than setpoint requiring more fresh air. See figure 34.

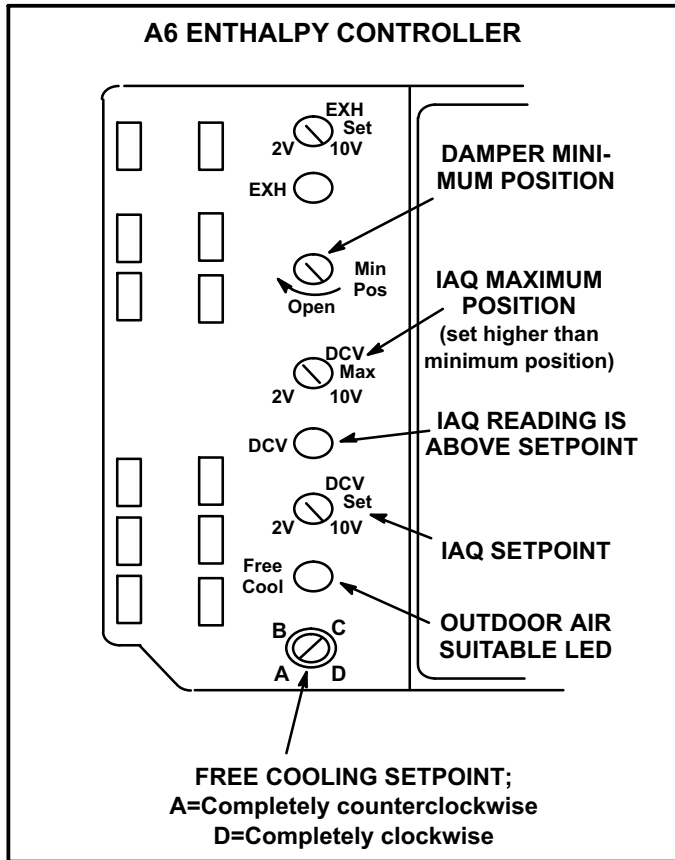

FIGURE 34

Free Cooling Setpoint

Outdoor air is considered suitable when temperature and humidity are less than the free cooling setpoints shown in table 18. Setting A is recommended. See figure 34. At setting A, free cooling will be energized when outdoor air is approximately 73°F (23°C) and 50% relative humidity. If indoor air is too warm or humid, lower the setpoint to B. At setting B, free cooling will be energized at 70°F (21°C) and 50% relative humidity.

When an optional A62 differential sensor is installed, turn A6 enthalpy control free cooling setpoint potentiometer completely clockwise to position "D".

TABLE 18
ENTHALPY CONTROL SETPOINTS

Control Setting	Free Cooling Setpoint At 50% RH
A	73° F (23° C)
B	70° F (21° C)
C	67° F (19° C)
D	63° F (17° C)

Damper Minimum Position

NOTE - A jumper is factory-installed between TB1 A1 and A2 terminals to maintain occupied status (allowing minimum fresh air). When using an electronic thermostat or energy management system with an occupied/unoccupied feature, remove jumper.

1- Set thermostat to occupied mode if the feature is available. Make sure jumper is in place between A45 control board TB1 terminals A1 and A2 if using a thermostat which does not have the feature.

2- Rotate MIN POS SET potentiometer to approximate desired fresh air percentage.

Note - Damper minimum position can be set lower than traditional minimum air requirements when an IAQ sensor is specified. Dampers will open to DCV MAX setting (if CO2 is above setpoint) to meet traditional ventilation requirements.

3- Measure outdoor air temperature. Mark the point on the bottom line of chart 1 and label the point "A" (40°F, 4°C shown).

4- Measure return air temperature. Mark that point on the top line of chart 1 and label the point "B" (74°F, 23°C shown).

5- Measure mixed air (outdoor and return air) temperature. Mark that point on the top line of chart 1 and label point "C" (70°F, 21°C shown).

6- Draw a straight line between points A and B.

7- Draw a vertical line through point C.

8- Draw a horizontal line where the two lines meet. Read the percent of fresh air intake on the side.

9- If fresh air percentage is less than desired, adjust MIN POS SET potentiometer higher. If fresh air percentage is more than desired, adjust MIN POS SET potentiometer lower. Repeat steps 3 through 8 until calculation reads desired fresh air percentage.

**CHART 1
CALCULATE MINIMUM FRESH AIR PERCENTAGE
MIXED AND RETURN AIR TEMPERATURE**

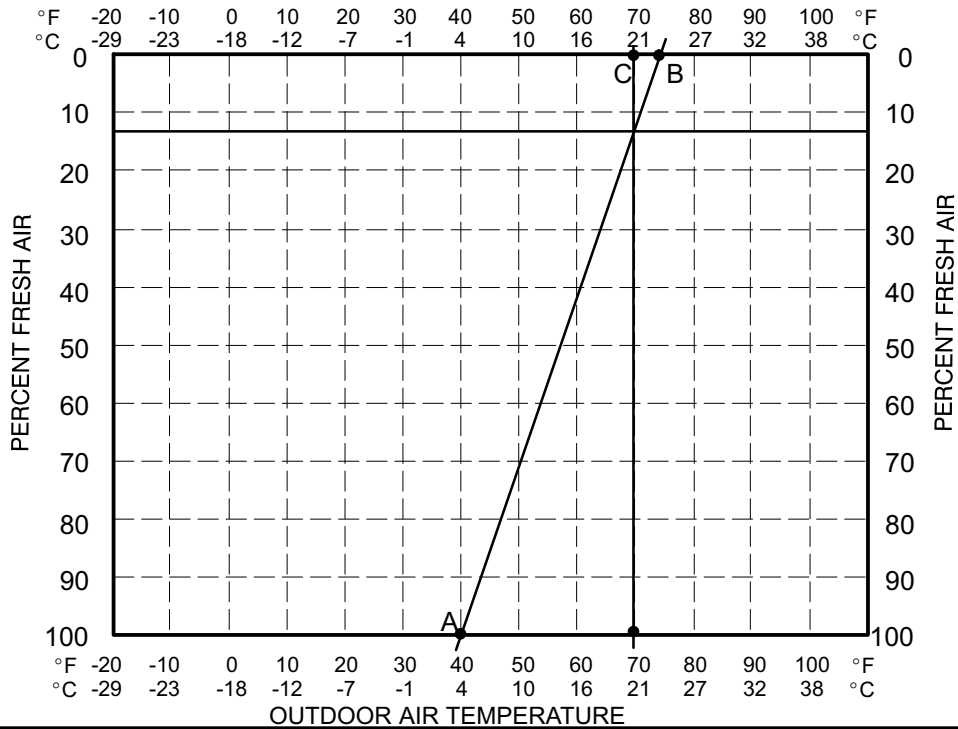

DCV Set and Max Settings

Adjust settings when an optional IAQ sensor is installed.

The DCV SET potentiometer is factory-set at approximately 50% of the potentiometer range. Using a standard 1-2000ppm CO₂ sensor, dampers will start to open when the IAQ sensor reads approximately 1000ppm. Adjust the DCV SET potentiometer to the approximate setting specified by the controls contractor. Refer to figure 34.

The DCV MAX potentiometer is factory-set at approximately 50% of the potentiometer range or 6VDC. Dampers will open approximately half way when CO₂ rises above setpoint. Adjust the DCV MAX potentiometer to the approximate setting specified by the controls contractor. Refer to figure 34.

Note - DCV Max must be set higher than economizer minimum position setting for proper demand control ventilation.

Economizer Operation

The occupied time period is determined by the thermostat or energy management system.

Outdoor Air Not Suitable:

During the unoccupied time period dampers are closed.

During the occupied time period a cooling demand will open dampers to minimum position and mechanical cooling functions normally.

During the occupied time period dampers will open to DCV MAX when IAQ reading is above setpoint (regardless of thermostat demand or outdoor air suitability).

Outdoor Air Suitable:

See table 19 for economizer operation with a standard two-stage thermostat.

During the occupied period, dampers will open to DCV MAX when IAQ reading is above setpoint (regardless of thermostat demand or outdoor air suitability). DCV MAX will NOT override damper full-open position. When an R1 mixed air sensor for modulating dampers is installed, DCV MAX may override damper free cooling position when occupancy is high and outdoor air temperatures are low. If R1 senses discharge air temperature below 45°F (7°C), dampers will move to minimum position until discharge air temperature rises to 48°F (9°C).

TABLE 19

ECONOMIZER OPERATION - OUTDOOR AIR IS SUITABLE FOR FREE COOLING – FREE COOL LED “ON”

THERMOSTAT DEMAND	DAMPER POSITION		MECHANICAL COOLING
	UNOCCUPIED	OCCUPIED	
OFF	CLOSED	CLOSED	NO
G	CLOSED	MINIMUM	NO
Y1	OPEN*	OPEN*	NO
Y2	OPEN*	OPEN*	STAGE 1

* Dampers will open to maintain 55°F (13°C) supply air when an R1 mixed air sensor is installed.

Outdoor Air Dampers

Optional manual and motorized outdoor air dampers provide fresh outdoor air. The motorized damper assembly opens to minimum position during the occupied time period and remains closed during the unoccupied period. Manual damper assembly is set at installation and remains in that position.

Set damper minimum position in the same manner as economizer minimum position. Adjust motorized damper position using the thumbwheel on the damper motor. See figure 35. Manual damper fresh air intake percentage can be determined in the same manner.

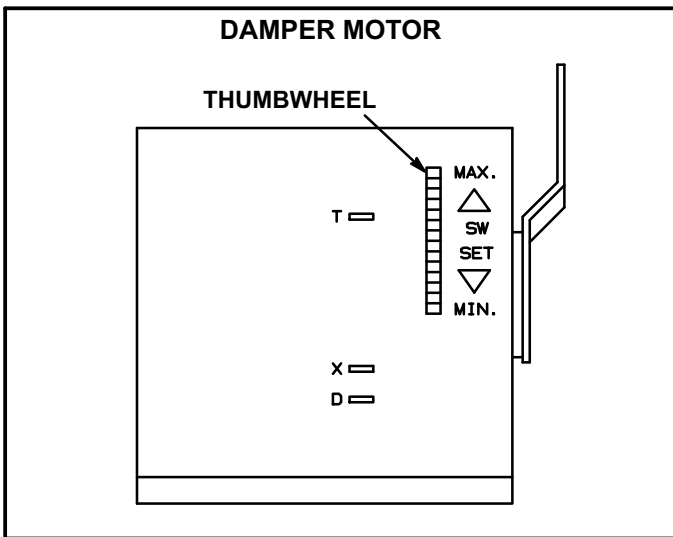

FIGURE 35

F-Barometric Relief Dampers

Dampers are used in downflow (see figure 36) and horizontal (see figure 37) air discharge applications. Horizontal barometric relief dampers are installed in the return air duct. The dampers must be used any time an economizer and a power exhaust fan is applied to KHA/KHB series units.

Barometric relief dampers allow exhaust air to be discharged from the system when an economizer and/or power exhaust is operating. Barometric relief dampers also prevent outdoor air infiltration during unit off cycle. See installation instructions for more detail.

NOTE- Barometric relief damper is optional except required with power exhaust dampers.

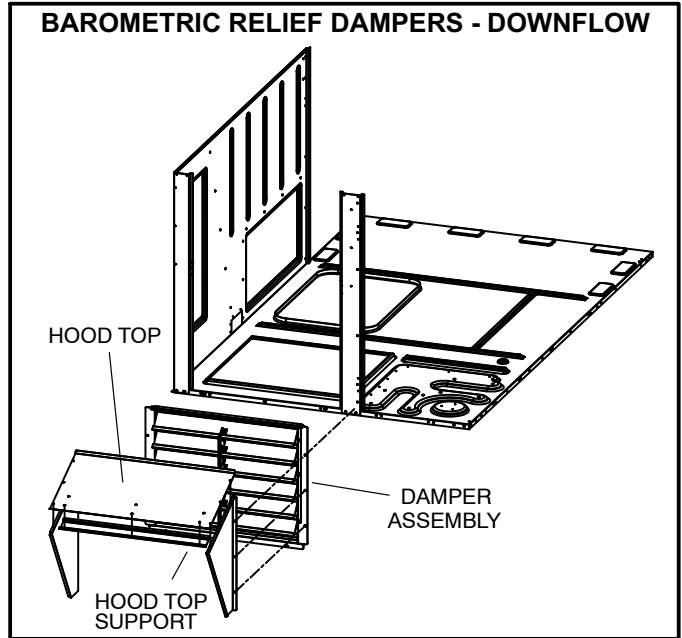

FIGURE 36

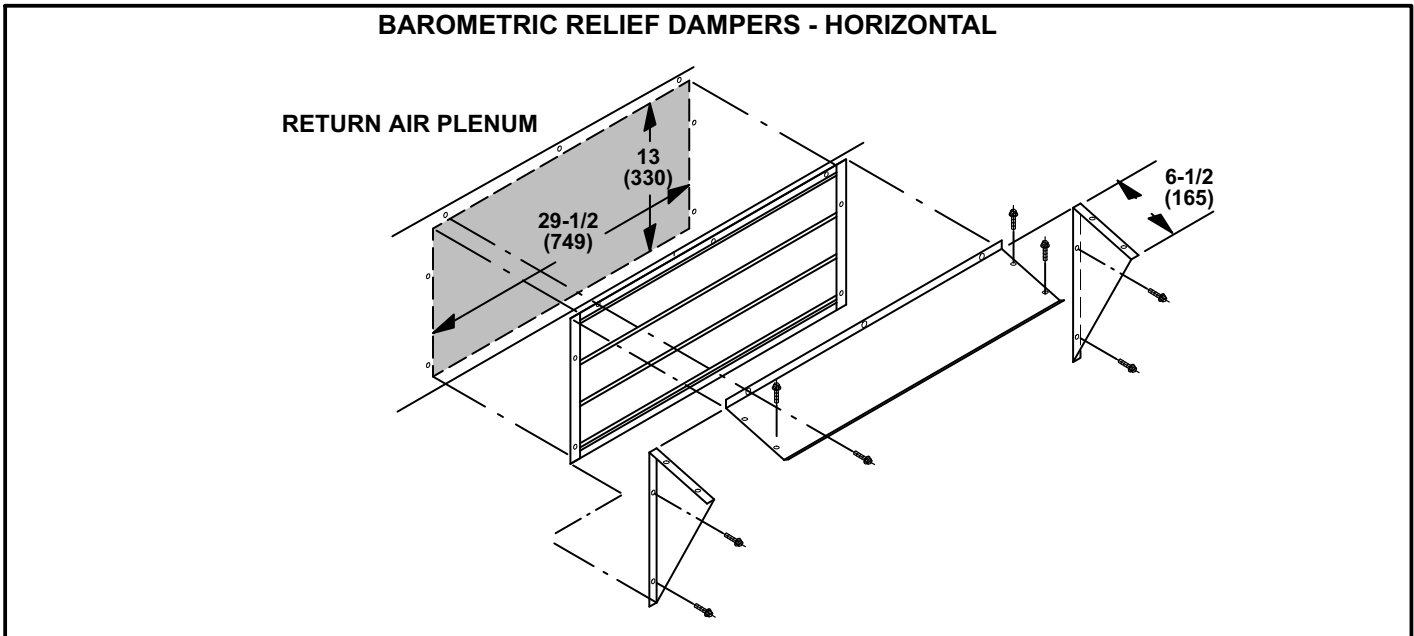

FIGURE 37

G-Power Exhaust Fan

The power exhaust fan (K1PWRE10B) requires an optional gravity exhaust damper and economizer and is used in downflow applications only. See figure 38. The power exhaust fan provides exhaust air pressure relief and also runs when return air dampers are closed and the supply air blower is operating. See installation instructions for more detail.

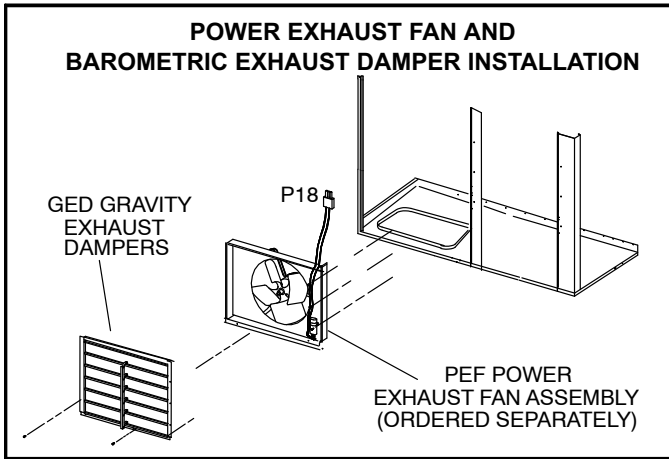

FIGURE 38

Power Exhaust Setpoint Adjustment

Locate the A6 enthalpy control in the control area. The EXH SET potentiometer is factory-set at approximately 50% of the dial range. See figure 39. Power exhaust fans will be energized 30 seconds after dampers are 50% open. Adjust the EXH SET potentiometer higher (clockwise toward 10V) to energize fans when dampers are further open. Adjust the EXH SET potentiometer lower (counterclockwise toward 2V) to energize fans when dampers are further closed. (Thirty-second delay allows dampers to partially open before exhaust fan starts.)

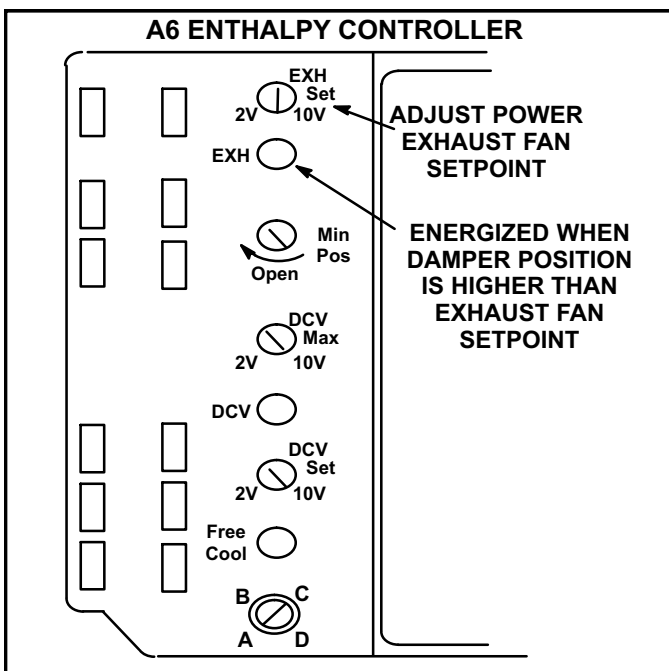

FIGURE 39

H-Control Systems

Three different types of control systems may be used with the KHA/KHB series units. All thermostat wiring is connected to terminal block TB1. Each thermostat has additional control options available. See thermostat installation instructions for more detail.

NOTE-KHA/KHB heat pumps use standard heat cool type thermostats. Attempted use of heat pump-type thermostat on KHA/KHB unit will result in improper operation.

1- Electro-mechanical thermostat (13F06)

The electro-mechanical thermostat is a two stage heat / two stage cool thermostat with dual temperature levers. A non-switching or manual system switch subbase may be used.

2- Electronic thermostat (see price book)

Any two stage heat / two stage cool electronic thermostat may be used.

3- Honeywell T7300 thermostat (37L54)

The Honeywell T7300 thermostat is a programmable, internal or optional remote temperature sensing thermostat. The T7300 provides occupied and unoccupied changeover control.

I-Smoke Detectors A171 and A172

Photoelectric smoke detectors are a field installed option. The smoke detectors can be installed in the supply air section (A64), return air section (A17), or in both the supply and return air section.

J-Drain Pan Overflow Switch S149 (optional)

The overflow switch is used to interrupt cooling operation when excessive condensate collects in the drain pan. The N.O. overflow switch is controlled by K220 and DL46 relays, located in the unit control panel. When the overflow switch closes, 24VAC power is interrupted and after a five-second delay unit compressors are de-energized. Once the condensate level drops below the set level, the switch will open. After a five-minute delay the compressor will be energized.

VII- WIRING DIAGRAMS / SEQUENCE OF OPERATION

KHA092/150 UNIT WIRING SCHEMATIC

24V POWER

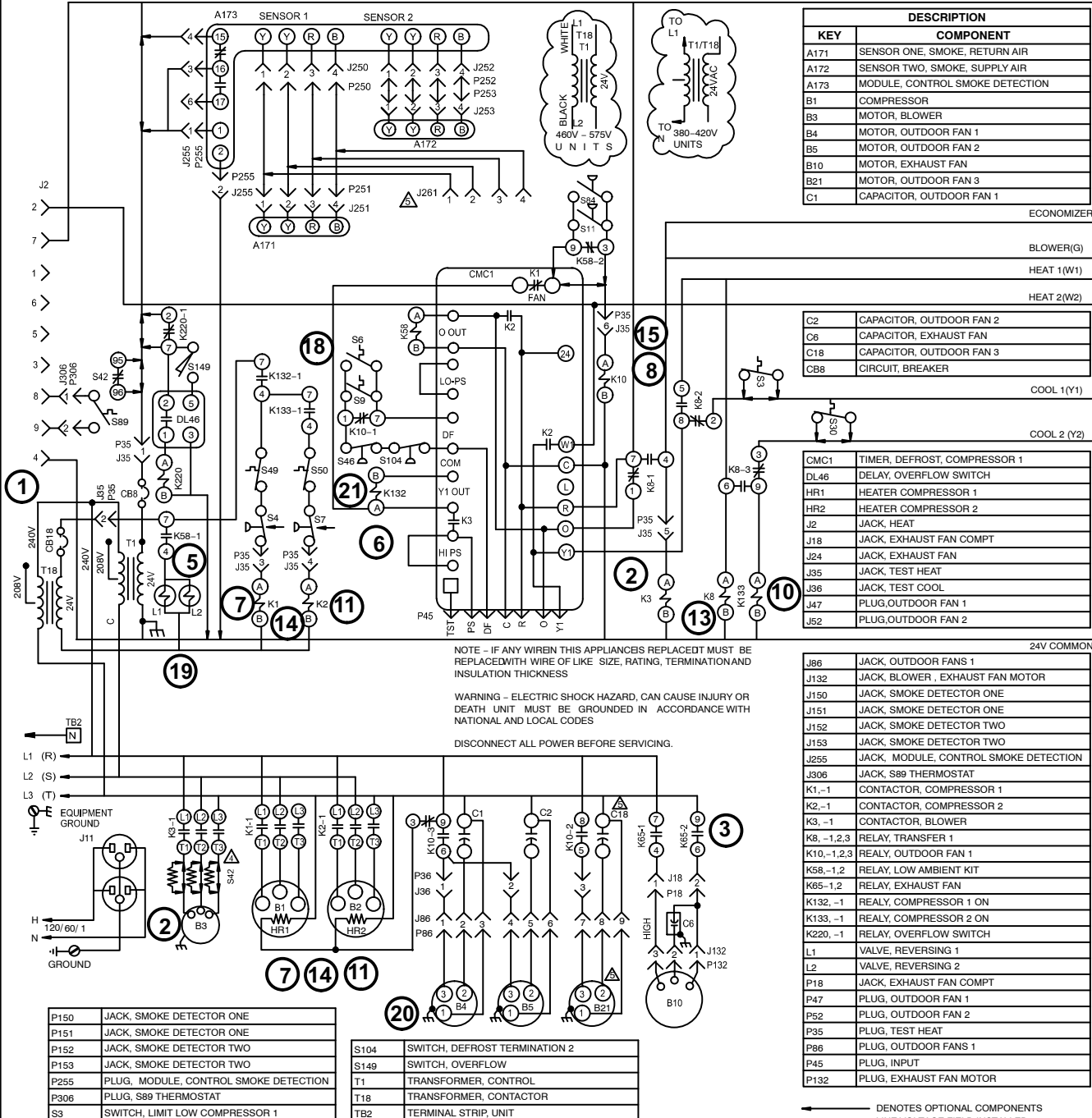

DESCRIPTION	
KEY	COMPONENT
A171	SENSOR ONE, SMOKE, RETURN AIR
A172	SENSOR TWO, SMOKE, SUPPLY AIR
A173	MODULE, CONTROL SMOKE DETECTION
B1	COMPRESSOR
B3	MOTOR, BLOWER
B4	MOTOR, OUTDOOR FAN 1
B5	MOTOR, OUTDOOR FAN 2
B10	MOTOR, EXHAUST FAN
B21	MOTOR, OUTDOOR FAN 3
C1	CAPACITOR, OUTDOOR FAN 1

ECONOMIZER	
BLOWER(G)	
HEAT 1(W1)	
HEAT 2(W2)	
C2	CAPACITOR, OUTDOOR FAN 2
C6	CAPACITOR, EXHAUST FAN
C18	CAPACITOR, OUTDOOR FAN 3
CB8	CIRCUIT, BREAKER
COOL 1(Y1)	
COOL 2(Y2)	

CMC1	TIMER, DEFROST, COMPRESSOR 1
DL46	DELAY, OVERFLOW SWITCH
HR1	HEATER COMPRESSOR 1
HR2	HEATER COMPRESSOR 2
J2	JACK, HEAT
J18	JACK, EXHAUST FAN COMPT
J24	JACK, EXHAUST FAN
J35	JACK, TEST HEAT
J36	JACK, TEST COOL
J47	PLUG, OUTDOOR FAN 1
J52	PLUG, OUTDOOR FAN 2

24V COMMON	
J86	JACK, OUTDOOR FANS 1
J132	JACK, BLOWER, EXHAUST FAN MOTOR
J150	JACK, SMOKE DETECTOR ONE
J151	JACK, SMOKE DETECTOR ONE
J152	JACK, SMOKE DETECTOR TWO
J153	JACK, SMOKE DETECTOR TWO
J255	JACK, MODULE, CONTROL SMOKE DETECTION
J306	JACK, S89 THERMOSTAT
K1,-1	CONTACTOR, COMPRESSOR 1
K2,-1	CONTACTOR, COMPRESSOR 2
K3,-1	CONTACTOR, BLOWER
K8,-1,2,3	RELAY, TRANSFER 1
K10,-1,2,3	RELAY, OUTDOOR FAN 1
K58,-1,2	RELAY, LOW AMBIENT KIT
K65,-1,2	RELAY, EXHAUST FAN
K132,-1	RELAY, COMPRESSOR 1 ON
K133,-1	RELAY, COMPRESSOR 2 ON
K220,-1	RELAY, OVERFLOW SWITCH
L1	VALVE, REVERSING 1
L2	VALVE, REVERSING 2
P18	JACK, EXHAUST FAN COMPT
P47	PLUG, OUTDOOR FAN 1
P52	PLUG, OUTDOOR FAN 2
P35	PLUG, TEST HEAT
P86	PLUG, OUTDOOR FANS 1
P45	PLUG, INPUT
P132	PLUG, EXHAUST FAN MOTOR

NOTE - IF ANY WIRE IN THIS APPLIANCE IS REPLACED IT MUST BE REPLACED WITH WIRE OF LIKE SIZE, RATING, TERMINATION AND INSULATION THICKNESS

WARNING - ELECTRIC SHOCK HAZARD, CAN CAUSE INJURY OR DEATH. UNIT MUST BE GROUNDED IN ACCORDANCE WITH NATIONAL AND LOCAL CODES

DISCONNECT ALL POWER BEFORE SERVICING.

P150	JACK, SMOKE DETECTOR ONE
P151	JACK, SMOKE DETECTOR ONE
P152	JACK, SMOKE DETECTOR TWO
P153	JACK, SMOKE DETECTOR TWO
P255	PLUG, MODULE, CONTROL SMOKE DETECTION
P306	PLUG, S89 THERMOSTAT
S3	SWITCH, LIMIT LOW COMPRESSOR 1
S4	SWITCH, LIMIT HI PRESS (MANUAL RESET)
S6	SWITCH, DEFROST COMPRESSOR 1
S7	SWITCH, LIMIT HI PRESS COMP 2
S9	SWITCH, DEFROST COMPRESSOR 2
S11	SWITCH, LOW PRESS, LOW AMBIENT KIT
S30	SWITCH, LIMIT HI COMPRESSOR 2
S42	SWITCH, OVERLOAD RELAY BLOWER MOTOR
S46	SWITCH, DEFROST TERMINATION
S49	SWITCH, FREEZE STAT
S50	SWITCH, FREEZE STAT 2
S84	SWITCH, LOW PRESS, LOW AMB COMP 2
S89	SWITCH, THERMOSTAT DISCHARGE TEMP

S104	SWITCH, DEFROST TERMINATION 2
S149	SWITCH, OVERFLOW
T1	TRANSFORMER, CONTROL
T18	TRANSFORMER, CONTACTOR
TB2	TERMINAL STRIP, UNIT

- ▲ NOTE - FOR USE WITH COPPER CONDUCTORS ONLY REFER TO UNIT RATING PLATE FOR MINIMUM CIRCUIT AMPACITY AND MAXIMUM OVERCURRENT PROTECTION SIZE.
- ▲ TB2 IS USED ON "M" VOLTAGE UNITS ONLY
- ▲ IMPORTANT: TO PREVENT MOTOR BURNOUT, NEVER CONNECT MORE THAN ONE MOTOR LEAD TO ANY ONE CONNECTION. TAPE UNUSED MOTOR LEADS
- ▲ S42 USED ON "M" VOLTAGE UNITS AND UNITS WITH HIGH EFFICIENCY MOTORS
- ▲ CONNECT A172 SENSOR TO J261 ON SUPPLY AIR SMOKE DETECTOR ONLY
- ▲ B21 AND C18 ARE USED ON -150 UNITS ONLY

WIRING DIAGRAM		12/09
COOLING		
KHA, - 092, 102, 120, 150 - G, J, M, Y		
SECTION B		REV. 1
Supersedes	New Form No. 537076-01	

SEQUENCE OF OPERATION KHA092/150

Power:

- 1- Line voltage from unit disconnect energizes transformer T1 and T18. T1 provides 24VAC power to terminal strip TB1. TB1 provides 24VAC to the unit cooling, heating and blower controls and thermostat. T18 provides 24VAC to K1 and K2 relay coils and L1 and L2 reversing valves.

Blower Operation:

- 2- Indoor thermostat terminal G energizes blower contactor K3 with 24VAC. N.O. K3 closes, energizing B3.

Economizer Operation:

- 3- The EXH (power exhaust set point) found on the face of A6, is factory set at approximate 50% of the dial range. Economizer control module A6 receives a demand and opens outside dampers 50%. Power exhaust fan relay K65 is energized 30 seconds after dampers are 50% open. K65-1 and K65-2 close, energizing power exhaust fan B10.

First Stage Cooling Demand (compressor B1)

- 4- First stage cooling demand energizes Y1 and G in the thermostat. G energizes blower (see step 2-)
- 5- Transformer T18 energizes reversing valves L1 and L2 via K58-1.
- 6- Y1 demand energizes K132 relay coil which closes K132-1 N.O. contacts and routes 24VAC to S49 N.C. freezestat and S4 N.C. high pressure switch. Compressor contactor K1 is energized.
- 7- K1 closes energizing compressor B1.
- 8- Y1 signal from CMC1 module energizes K10 relay coil. K10-3 N.C. and K10-2 (KHA/KHB150 only) N.O. contacts close energizing outdoor fan B4, B5 and B21 (KHA/KHB150 only).

Second Stage Cooling Demand (compressor B2)

- 9- Second stage cooling demand energizes Y2.
- 10- Y2 demand energizes relay K133 relay coil which closes K133-1 N.O. contacts. 24VAC is routed to S50 N.C. freezestat and S7 N.C. high pressure switch. Compressor contactor K2 is energized.
- 11- K2 closes energizing compressor B2.

First Stage Heat (compressors B1 and B2)

- 12- Heating demand energizes W1 in the thermostat.
- 13- W1 demand energizes K8 relay coil which closes K8-2 and K8-3 N.O. contacts and K132 and K133 coils. 24VAC is routed to K1 and K2 contactors
- 14- K1 and K2 close energizing compressor B1 and B2.
- 15- 24VAC from CMC1 module energizes K10 relay coil. K10-3 N.O. contacts and K10-2 (KHA/KHB150 only) N.O. contacts close energizing outdoor fans B4, B5, and B21 (KHA/KHB150 only).

Second Stage Heat (electric heat):

- 16- Second stage heat demand energizes W2 in the thermostat.
- 17- See sequence of operation for electric heat.

Defrost Mode:

- 18- During heating operation, when outdoor coil drops to $35 \pm 4^\circ$ the defrost thermostat S6 or S9 closes initiating defrost (after minimum run time of 30, 60 or 90 minutes).
- 19- When defrost begins, the reversing valve L1 or L2 is energized. Supplemental electric heat (W2) is energized.
- 20- When L1 energizes, outdoor fan relay K10 and outdoor fans B4, B5, and B21 are de-energized.
- 21- Defrost terminates when the pressure switch for the circuit S46 or S104 opens, or when 15 minutes has elapsed. The defrost cycle is **not** terminated when thermostat demand ends.

KHB092/102-CAV UNIT WIRING SCHEMATIC

24V POWER

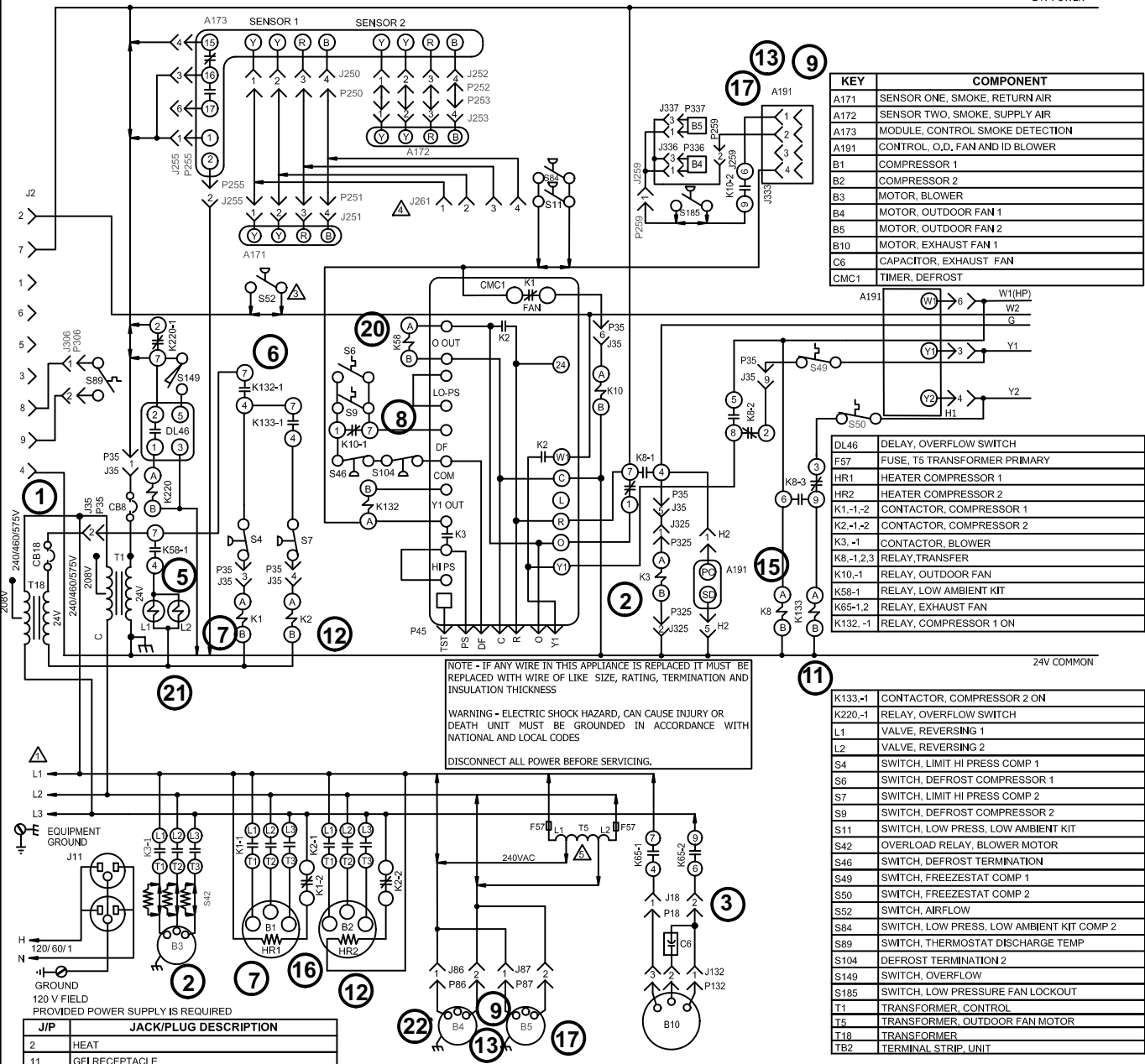

KEY	COMPONENT
A171	SENSOR ONE, SMOKE, RETURN AIR
A172	SENSOR TWO, SMOKE, SUPPLY AIR
A173	MODULE, CONTROL SMOKE DETECTION
A191	CONTROL, O.D. FAN AND ID BLOWER
B1	COMPRESSOR 1
B2	COMPRESSOR 2
B3	MOTOR, BLOWER
B4	MOTOR, OUTDOOR FAN 1
B5	MOTOR, OUTDOOR FAN 2
B10	MOTOR, EXHAUST FAN 1
C6	CAPACITOR, EXHAUST FAN
CMC1	TIMER, DEFROST

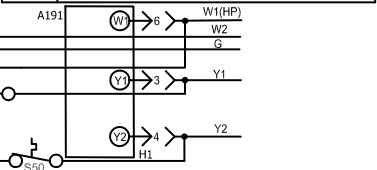

DL46	DELAY, OVERFLOW SWITCH
F57	FUSE, T5 TRANSFORMER PRIMARY
HR1	HEATER COMPRESSOR 1
HR2	HEATER COMPRESSOR 2
K1,-1,-2	CONTACTOR, COMPRESSOR 1
K2,-1,-2	CONTACTOR, COMPRESSOR 2
K3,-1	CONTACTOR, BLOWER
K8,-1,2,3	RELAY, TRANSFER
K10,-1	RELAY, OUTDOOR FAN
K58-1	RELAY, LOW AMBIENT KIT
K65-1,2	RELAY, EXHAUST FAN
K132,-1	RELAY, COMPRESSOR 1 ON

NOTE - IF ANY WIRE IN THIS APPLIANCE IS REPLACED IT MUST BE REPLACED WITH WIRE OF LIKE SIZE, RATING, TERMINATION AND INSULATION THICKNESS

WARNING - ELECTRIC SHOCK HAZARD, CAN CAUSE INJURY OR DEATH. UNIT MUST BE GROUNDED IN ACCORDANCE WITH NATIONAL AND LOCAL CODES

DISCONNECT ALL POWER BEFORE SERVICING.

K133,-1	CONTACTOR, COMPRESSOR 2 ON
K220,-1	RELAY, OVERFLOW SWITCH
L1	VALVE, REVERSING 1
L2	VALVE, REVERSING 2
S4	SWITCH, LIMIT HI PRESS COMP 1
S6	SWITCH, DEFROST COMPRESSOR 1
S7	SWITCH, LIMIT HI PRESS COMP 2
S9	SWITCH, DEFROST COMPRESSOR 2
S11	SWITCH, LOW PRESS, LOW AMBIENT KIT
S42	OVERLOAD RELAY, BLOWER MOTOR
S46	SWITCH, DEFROST TERMINATION
S49	SWITCH, FREEZESTAT COMP 1
S50	SWITCH, FREEZESTAT COMP 2
S52	SWITCH, AIRFLOW
S84	SWITCH, LOW PRESS, LOW AMBIENT KIT COMP 2
S89	SWITCH, THERMOSTAT DISCHARGE TEMP
S104	DEFROST TERMINATION 2
S149	SWITCH, OVERFLOW
S185	SWITCH, LOW PRESSURE FAN LOCKOUT
T1	TRANSFORMER, CONTROL
T5	TRANSFORMER, OUTDOOR FAN MOTOR
T18	TRANSFORMER
TB2	TERMINAL STRIP, UNIT

PROVIDED POWER SUPPLY IS REQUIRED

J/P	JACK/PLUG DESCRIPTION
2	HEAT
11	GFI RECEPTACLE
18	EXHAUST FAN COMPT
35	TEST HEAT
36	TEST COOL
86	OUTDOOR FANS 1
87	OUTDOOR FANS 2
132	EXHAUST FAN MOTOR 1
250	SMOKE DETECTOR ONE
251	SMOKE DETECTOR ONE
252	SMOKE DETECTOR TWO
253	SMOKE DETECTOR TWO
255	MODULE, CONTROL SMOKE DETECTION
259	BLOWER ECM MOTOR
261	SMOKE DETECTOR JUMPER
333	0-5V TRANSDUCER INPUT

336	OD FAN CONTROL, B4
337	OD FAN CONTROL, B5

- ⚠ NOTE - FOR USE WITH COPPER CONDUCTORS ONLY REFER TO UNIT RATING PLATE FOR MINIMUM CIRCUIT AMPACITY AND MAXIMUM OVERCURRENT PROTECTION SIZE.
- ⚠ IMPORTANT: TO PREVENT MOTOR BURNOUT, NEVER CONNECT MORE THAN ONE MOTOR LEAD TO ANY ONE CONNECTION. TAPE UNUSED MOTOR LEADS
- ⚠ UNITS WITH SCR OPTION ONLY
- ⚠ CONNECT A172 SENSOR TO J261 ON SUPPLY AIR SMOKE DETECTOR ONLY
- ⚠ T5 USED ON G AND J VOLTAGE ONLY

— DENOTES OPTIONAL COMPONENTS
 — LINE VOLTAGE FIELD INSTALLED

04/16	WIRING DIAGRAM 537851-01 COOLING - CAV KHB 092,102 - G,J,Y	04/16
SECTION B		REV. 0
Supersedes		New Form No. 537851-01

KHB092/102 VFD UNIT WIRING SCHEMATIC

24V POWER

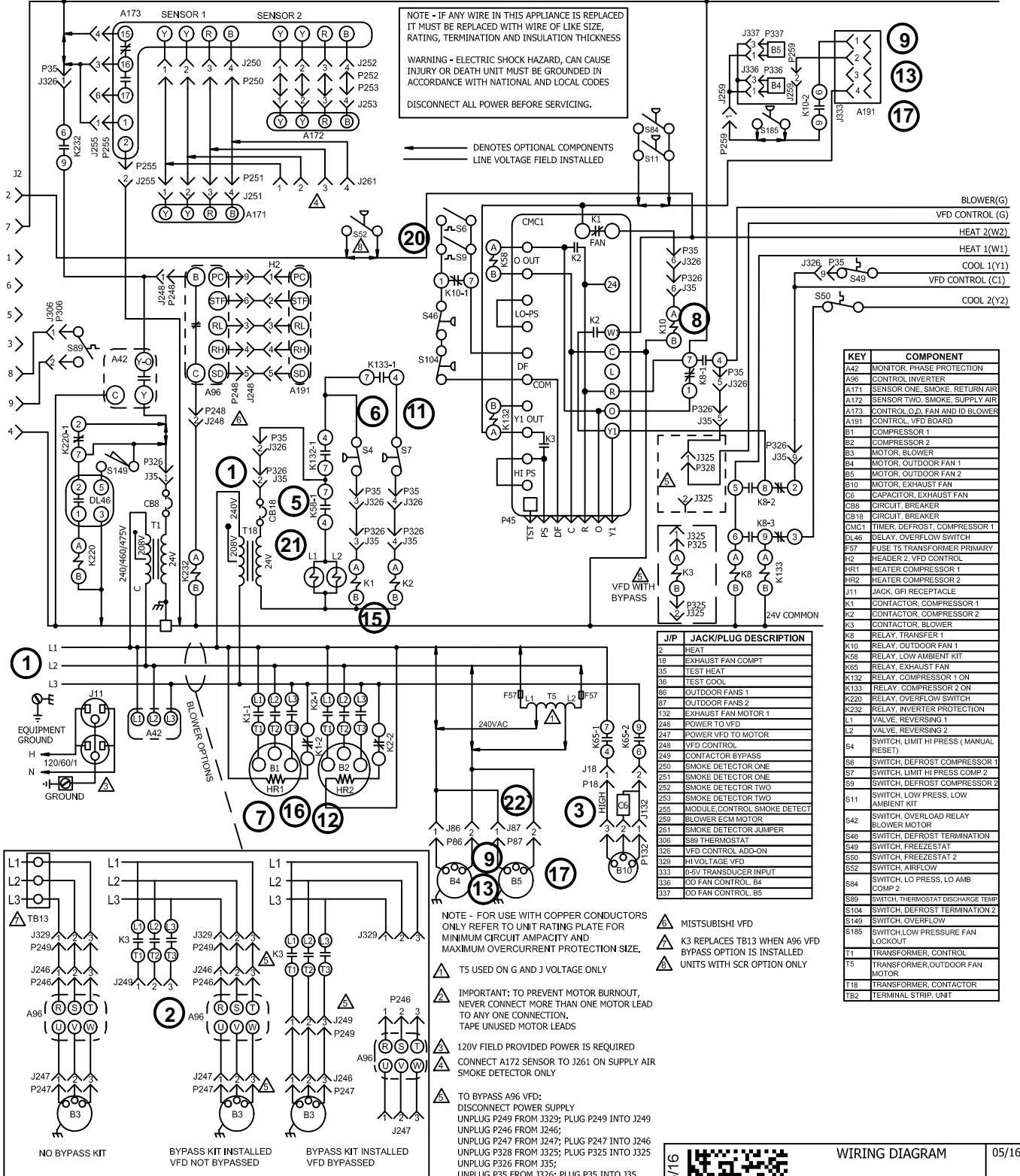

KEY	COMPONENT
A42	MONITOR, PHASE PROTECTION
A96	CONTROL INVERTER
A171	SENSOR ONE, SMOKE, RETURN AIR
A172	SENSOR TWO, SMOKE, SUPPLY AIR
A173	CONTROL, CO, FAN AND ID BLOWER
A191	CONTROL, VFD BOARD
B1	COMPRESSOR 1
B2	COMPRESSOR 2
B3	MOTOR, BLOWER
B4	MOTOR, OUTDOOR FAN 1
B5	MOTOR, OUTDOOR FAN 2
B10	MOTOR, EXHAUST FAN
C3	CAPACITOR, EXHAUST FAN
C88	CIRCUIT BREAKER
CMC1	TIMER, DEFROST, COMPRESSOR 1
DL46	DELAY, OVER/LOW SWITCH
F57	FUSE T5 TRANSFORMER PRIMARY
H2	HEADER 2, VFD CONTROL
HR1	HEATER COMPRESSOR 1
HR2	HEATER COMPRESSOR 2
J11	JACK, GFI RECEPTACLE
K1	CONTACTOR, COMPRESSOR 1
K2	CONTACTOR, COMPRESSOR 2
K3	CONTACTOR, BLOWER
K8	RELAY, TRANSFER 1
2	HEAT
18	EXHAUST FAN COMPT
35	TEST HEAT
36	TEST COOL
86	OUTDOOR FANS 1
87	OUTDOOR FANS 2
132	EXHAUST FAN MOTOR 1
246	POWER TO VFD
247	VFD CONTROL
249	CONTACTOR BYPASS
250	SMOKE DETECTOR ONE
251	SMOKE DETECTOR ONE
252	SMOKE DETECTOR TWO
253	SMOKE DETECTOR TWO
255	MODULE CONTROL, SMOKE DETECT
259	BLOWER ECM MOTOR
281	SMOKE DETECTOR JUMPER
306	S89 THERMOSTAT
326	VFD CONTROL ADD-ON
329	HI VOLTAGE VFD
333	0-5V TRANSDUCER INPUT
336	OD FAN CONTROL, B4
337	OD FAN CONTROL, B5
K10	RELAY, OUTDOOR FAN 1
C88	RELAY, LOW AMBIENT KIT
K65	RELAY, EXHAUST FAN
K132	RELAY, COMPRESSOR 1 ON
K133	RELAY, COMPRESSOR 2 ON
K220	RELAY, OVER/LOW SWITCH
K232	RELAY, INVERTER PROTECTION
L1	VALVE, REVERSING 1
L2	VALVE, REVERSING 2
S4	SWITCH, LIMIT HI PRESS (MANUAL RESET)
S6	SWITCH, DEFROST COMPRESSOR 1
S7	SWITCH, LIMIT HI PRESS COMP 2
S9	SWITCH, DEFROST COMPRESSOR 2
S11	SWITCH, LOW PRESS, LOW AMBIENT KIT
S42	SWITCH, OVERLOAD RELAY BLOWER MOTOR
S46	SWITCH, DEFROST TERMINATION
S49	SWITCH, FREEZE/STAT
S50	SWITCH, FREEZE/STAT 2
S52	SWITCH, ABOVE/LOW
S84	SWITCH, LO PRESS, LO AMB COMP 2
S89	SWITCH, THERMOSTAT DISCHARGE TEMP
S104	SWITCH, DEFROST TERMINATION 2
S149	SWITCH, OVERFLOW
S185	SWITCH, LOW PRESSURE FAN LOCKOUT
T1	TRANSFORMER, CONTROL
T5	TRANSFORMER, OUTDOOR FAN MOTOR
T18	TRANSFORMER, CONTACTOR
TB2	TERMINAL STRIP, UNIT

J/P	JACK/PLUG DESCRIPTION
2	HEAT
18	EXHAUST FAN COMPT
35	TEST HEAT
36	TEST COOL
86	OUTDOOR FANS 1
87	OUTDOOR FANS 2
132	EXHAUST FAN MOTOR 1
246	POWER TO VFD
247	VFD CONTROL
249	CONTACTOR BYPASS
250	SMOKE DETECTOR ONE
251	SMOKE DETECTOR ONE
252	SMOKE DETECTOR TWO
253	SMOKE DETECTOR TWO
255	MODULE CONTROL, SMOKE DETECT
259	BLOWER ECM MOTOR
281	SMOKE DETECTOR JUMPER
306	S89 THERMOSTAT
326	VFD CONTROL ADD-ON
329	HI VOLTAGE VFD
333	0-5V TRANSDUCER INPUT
336	OD FAN CONTROL, B4
337	OD FAN CONTROL, B5

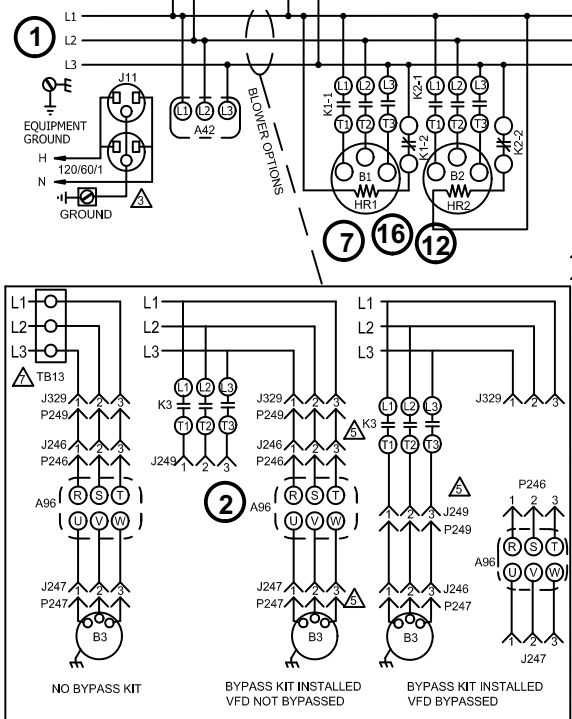

NOTE - FOR USE WITH COPPER CONDUCTORS ONLY REFER TO UNIT RATING PLATE FOR MINIMUM CIRCUIT AMPACITY AND MAXIMUM OVERCURRENT PROTECTION SIZE.

⚠ T5 USED ON G AND J VOLTAGE ONLY

⚠ IMPORTANT: TO PREVENT MOTOR BURNOUT, NEVER CONNECT MORE THAN ONE MOTOR LEAD TO ANY ONE CONNECTION. TAPE UNUSED MOTOR LEADS

⚠ 120V FIELD PROVIDED POWER IS REQUIRED CONNECT A172 SENSOR TO J261 ON SUPPLY AIR SMOKE DETECTOR ONLY

⚠ TO BYPASS A96 VFD: DISCONNECT POWER SUPPLY UNPLUG P249 FROM J329; PLUG P249 INTO J249 UNPLUG P246 FROM J246; UNPLUG P247 FROM J247; PLUG P247 INTO J246 UNPLUG P328 FROM J325; PLUG P325 INTO J325 UNPLUG P326 FROM J35; UNPLUG P35 FROM J326; PLUG P35 INTO J35

⚠ MISTSUBISHI VFD

⚠ K3 REPLACES TB13 WHEN A96 VFD BYPASS OPTION IS INSTALLED

⚠ UNITS WITH SCR OPTION ONLY



05/16

WIRING DIAGRAM 05/16

537850-01

COOLING

KHB- 092,102 - G,J,Y - VFD UNITS

SECTION B REV. 0

Supersedes New Form No. 537850-01

SEQUENCE OF OPERATION KHB092/102

Power:

- 1- Line voltage from unit disconnect energizes transformer T1 and T18. T1 provides 24VAC power to terminal strip TB1. TB1 provides 24VAC to the unit cooling, heating and fan control board and thermostat. T18 provides 24VAC to K1 and K2 relay coils and L1 and L2 reversing valves.

Blower Operation:

- 2- *VFD Units without a by-pass* - Indoor blower operation is controlled by A96 inverter.
VFD Units with a by-pass and CAV Units - Indoor thermostat terminal G energizes blower contactor K3 with 24VAC. N.O. K3 closes, energizing B3.

Economizer Operation:

- 3- The EXH (power exhaust set point) found on the face of A6, is factory set at approximate 50% of the dial range. Economizer control module A6 receives a demand and opens outside dampers 50%. Power exhaust fan relay K65 is energized 30 seconds after dampers are 50% open. K65-1 and K65-2 close, energizing power exhaust fan B10.

First Stage Cooling Demand (compressor B1)

- 4- First stage cooling demand energizes Y1 and G in the thermostat. G energizes blower (see step 2-)
- 5- Transformer T18 energizes reversing valves L1 and L2 via K58-1.
- 6- Y1 demand energizes K132 relay coil which closes K132-1 N.O. contacts and routes 24VAC to S49 N.C. freezestat and S4 N.C. high pressure switch. Compressor contactor K1 is energized.
- 7- K1-1 N.O. contacts close energizing compressor B1 and K1-2 N.C. contacts open de-energizing crankcase heater HR1.
- 8- Y1 signal from CMC1 module energizes K10 relay coil.
- 9- Fan control A191 energizes outdoor fan B4 and B5 on low speed..

Second Stage Cooling Demand (compressor B2)

- 10- Second stage cooling demand energizes Y2.
- 11- Y2 demand energizes relay K133 relay coil which closes K1331 N.O. contacts. 24VAC is routed to S50 N.C. freezestat and S7 N.C. high pressure switch. Compressor contactor K2 is energized.
- 12- K2-1 N.O. contacts close energizing compressor B2 and K2-2 N.C. contacts open de-energizing crankcase heater HR2.
- 13- Fan control A191 energizes outdoor fan B4 and B5 on high speed.

First Stage Heat (compressors B1 and B2)

- 14- Heating demand energizes W1 in the thermostat.
- 15- W1 demand energizes K8 relay coil which closes K8-2 and K8-3 N.O. contacts and K132 and K133 coils. 24VAC is routed to K1 and K2 contactors
- 16- K1 and K2 close energizing compressor B1 and B2 and de-energizing crankcase heaters HR1 and HR2.
- 17- 24VAC from CMC1 module energizes K10 relay coil. Fan control A191 energizes outdoor fans B4 and B5..

Second Stage Heat (electric heat):

- 18- Second stage heat demand energizes W2 in the thermostat.
- 19- See sequence of operation for electric heat.

Defrost Mode:

- 20- During heating operation, when outdoor coil drops to $35 \pm 4^\circ$ the defrost thermostat S6 or S9 closes initiating defrost (after minimum run time of 30, 60 or 90 minutes).
- 21- When defrost begins, the reversing valve L1 or L2 is energized. Supplemental electric heat (W2) is energized.
- 22- When L1 energizes, outdoor fan relay K10 and outdoor fans B4, B5, are de-energized.
- 23- Defrost terminates when the pressure switch for the circuit S46 or S104 opens, or when 15 minutes has elapsed. The defrost cycle is **not** terminated when thermostat demand ends.

KHB122 UNIT WIRING SCHEMATIC

24V POWER

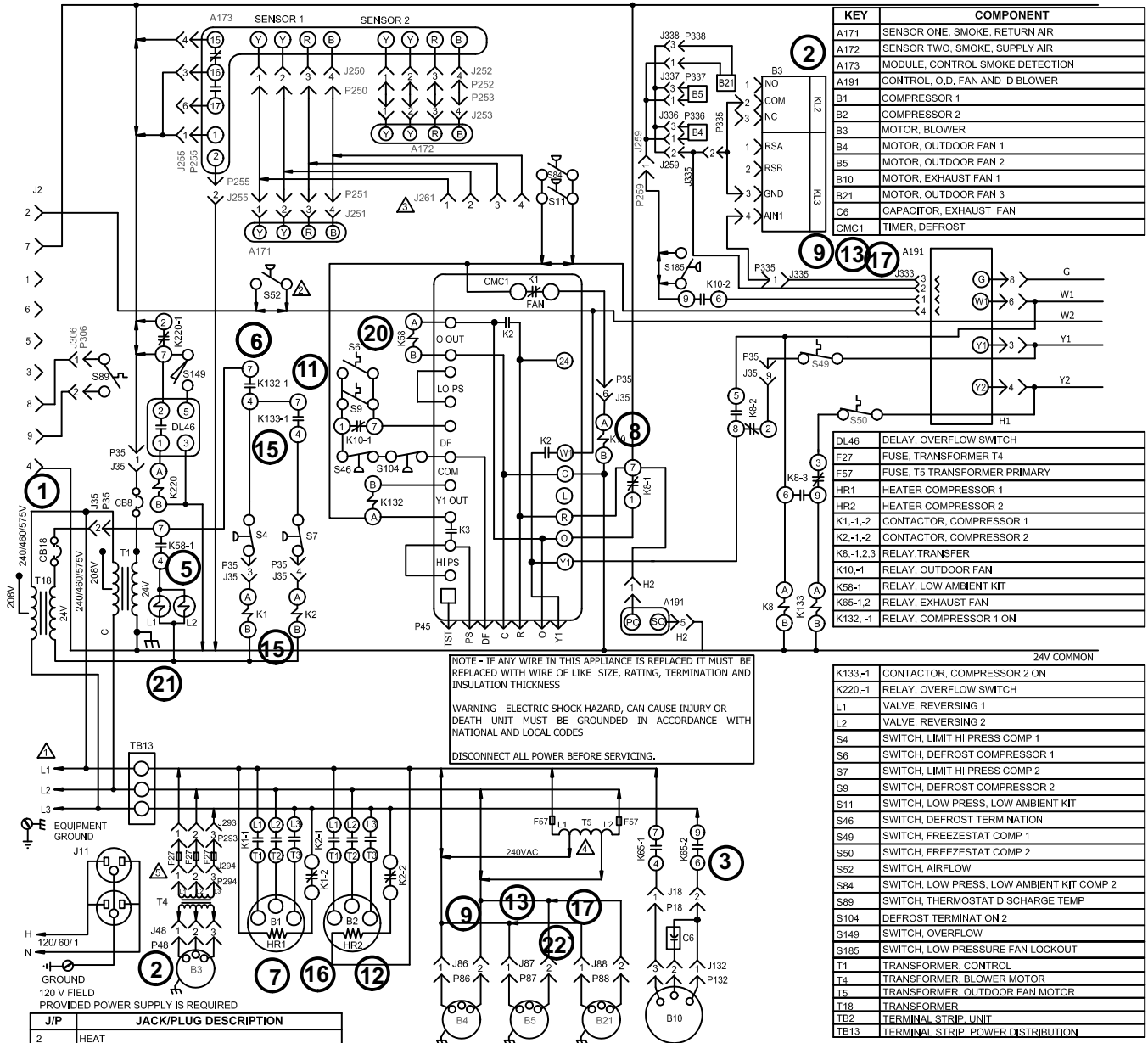

KEY	COMPONENT
A171	SENSOR ONE, SMOKE, RETURN AIR
A172	SENSOR TWO, SMOKE, SUPPLY AIR
A173	MODULE, CONTROL SMOKE DETECTION
A191	CONTROL, O.D. FAN AND ID BLOWER
B1	COMPRESSOR 1
B2	COMPRESSOR 2
B3	MOTOR, BLOWER
B4	MOTOR, OUTDOOR FAN 1
B5	MOTOR, OUTDOOR FAN 2
B10	MOTOR, EXHAUST FAN 1
B21	MOTOR, OUTDOOR FAN 3
C6	CAPACITOR, EXHAUST FAN
CMC1	TIMER, DEFROST

DL46	DELAY, OVERFLOW SWITCH
F27	FUSE, TRANSFORMER T4
F57	FUSE, T5 TRANSFORMER PRIMARY
HR1	HEATER COMPRESSOR 1
HR2	HEATER COMPRESSOR 2
K1,-1,2	CONTACTOR, COMPRESSOR 1
K2,-1,2	CONTACTOR, COMPRESSOR 2
K8,-1,2,3	RELAY, TRANSFER
K10,-1	RELAY, OUTDOOR FAN
K58-1	RELAY, LOW AMBIENT KIT
K65-1,2	RELAY, EXHAUST FAN
K132,-1	RELAY, COMPRESSOR 1 ON

NOTE - IF ANY WIRE IN THIS APPLIANCE IS REPLACED IT MUST BE REPLACED WITH WIRE OF LIKE SIZE, RATING, TERMINATION AND INSULATION THICKNESS.
 WARNING - ELECTRIC SHOCK HAZARD, CAN CAUSE INJURY OR DEATH. UNIT MUST BE GROUNDED IN ACCORDANCE WITH NATIONAL AND LOCAL CODES.
 DISCONNECT ALL POWER BEFORE SERVICING.

K133,-1	CONTACTOR, COMPRESSOR 2 ON
K220,-1	RELAY, OVERFLOW SWITCH
L1	VALVE, REVERSING 1
L2	VALVE, REVERSING 2
S4	SWITCH, LIMIT HI PRESS COMP 1
S6	SWITCH, DEFROST COMPRESSOR 1
S7	SWITCH, LIMIT HI PRESS COMP 2
S9	SWITCH, DEFROST COMPRESSOR 2
S11	SWITCH, LOW PRESS, LOW AMBIENT KIT
S46	SWITCH, DEFROST TERMINATION
S49	SWITCH, FREEZE/STAT COMP 1
S50	SWITCH, FREEZE/STAT COMP 2
S52	SWITCH, AIRFLOW
S84	SWITCH, LOW PRESS, LOW AMBIENT KIT COMP 2
S89	SWITCH, THERMOSTAT DISCHARGE TEMP
S104	DEFROST TERMINATION 2
S149	SWITCH, OVERFLOW
S185	SWITCH, LOW PRESSURE FAN LOCKOUT
T1	TRANSFORMER, CONTROL
T4	TRANSFORMER, BLOWER MOTOR
T5	TRANSFORMER, OUTDOOR FAN MOTOR
T18	TRANSFORMER
TB2	TERMINAL STRIP, UNIT
TB13	TERMINAL STRIP, POWER DISTRIBUTION

J/P	JACK/PLUG DESCRIPTION
2	HEAT
11	GFI RECEPTACLE
18	EXHAUST FAN COMPT
35	TEST HEAT
36	TEST COOL
48	MOTOR, FRESH AIR BLOWER
86	OUTDOOR FANS 1
87	OUTDOOR FANS 2
88	OUTDOOR FANS 3
132	EXHAUST FAN MOTOR 1
250	SMOKE DETECTOR ONE
251	SMOKE DETECTOR ONE
252	SMOKE DETECTOR TWO
253	SMOKE DETECTOR TWO
255	MODULE, CONTROL SMOKE DETECTION
259	BLOWER ECM MOTOR
261	SMOKE DETECTOR JUMPER

293	F27 LINE SIDE
294	F27 LOAD SIDE
333	0-5V TRANSDUCER INPUT
335	EBM CONTROL
336	OD FAN CONTROL, B4
337	OD FAN CONTROL, B5
338	OD FAN CONTROL, B21

NOTE - FOR USE WITH COPPER CONDUCTORS ONLY REFER TO UNIT RATING PLATE FOR MINIMUM CIRCUIT AMPACITY AND MAXIMUM OVERCURRENT PROTECTION SIZE.
 UNITS WITH SCR OPTION ONLY
 CONNECT A172 SENSOR TO J261 ON SUPPLY AIR SMOKE DETECTOR ONLY
 T5 USED ON G AND J VOLTAGE ONLY
 T4 USED ON J VOLTAGE ONLY

04/16 WIRING DIAGRAM 04/16
 537849-01
 COOLING
 KHB 122 - G,J,Y
 SECTION B
 Supersedes New Form No. 537849-01
 REV. 0

SEQUENCE OF OPERATION KHB122

Power:

- 1- Line voltage from unit disconnect energizes transformer T1 and T18. T1 provides 24VAC power to terminal strip TB1. TB1 provides 24VAC to the unit cooling, heating, fan control board and thermostat. T18 provides 24VAC to K1 and K2 relay coils and L1 and L2 reversing valves.

Blower Operation:

- 2- Indoor thermostat terminal G energizes blower fan control A191 energizing blower B3.

Economizer Operation:

- 3- The EXH (power exhaust set point) found on the face of A6, is factory set at approximate 50% of the dial range. Economizer control module A6 receives a demand and opens outside dampers 50%. Power exhaust fan relay K65 is energized 30 seconds after dampers are 50% open. K65-1 and K65-2 close, energizing power exhaust fan B10.

First Stage Cooling Demand (compressor B1)

- 4- First stage cooling demand energizes Y1 and G in the thermostat. G energizes blower (see step 2-)
- 5- Transformer T18 energizes reversing valves L1 and L2 via K58-1.
- 6- Y1 demand energizes K132 relay coil which closes K132-1 N.O. contacts and routes 24VAC to S49 N.C. freezestat and S4 N.C. high pressure switch. Compressor contactor K1 is energized.
- 7- K1-1 N.O. contacts close energizing compressor B1 and K1-2 N.C. contacts open de-energizing crankcase heater HR1.
- 8- Y1 signal from CMC1 module energizes K10 relay coil.
- 9- Fan control A191 energizes outdoor fan B4, B5 and B21 on low speed..

Second Stage Cooling Demand (compressor B2)

- 10- Second stage cooling demand energizes Y2.
- 11- Y2 demand energizes relay K133 relay coil which closes K1331 N.O. contacts. 24VAC is routed to S50 N.C. freezestat and S7 N.C. high pressure switch. Compressor contactor K2 is energized.
- 12- K2-1 N.O. contacts close energizing compressor B2 and K2-2 N.C. contacts open de-energizing crankcase heater HR2.
- 13- Fan control A191 energizes outdoor fan B4, B5 and B21 on high speed.

First Stage Heat (compressors B1 and B2)

- 14- Heating demand energizes W1 in the thermostat.
- 15- W1 demand energizes K8 relay coil which closes K8-2 and K8-3 N.O. contacts and K132 and K133 coils. 24VAC is routed to K1 and K2 contactors
- 16- K1 and K2 close energizing compressor B1 and B2 and de-energizing crankcase heaters HR1 and HR2.
- 17- 24VAC from CMC1 module energizes K10 relay coil. Fan control A191 energizes outdoor fans B4, B5 and B21..

Second Stage Heat (electric heat):

- 18- Second stage heat demand energizes W2 in the thermostat.
- 19- See sequence of operation for electric heat.

Defrost Mode:

- 20- During heating operation, when outdoor coil drops to $35 \pm 4^\circ$ the defrost thermostat S6 or S9 closes initiating defrost (after minimum run time of 30, 60 or 90 minutes).
- 21- When defrost begins, the reversing valve L1 or L2 is energized. Supplemental electric heat (W2) is energized.
- 22- When L1 energizes, outdoor fan relay K10 and outdoor fans B4, B5 and B21 are de-energized.
- 23- Defrost terminates when the pressure switch for the circuit S46 or S104 opens, or when 15 minutes has elapsed. The defrost cycle is **not** terminated when thermostat demand ends.

ELECTRONIC OR ELECTROMECHANICAL THERMOSTAT KHA/KHB SERIES UNITS

24V POWER

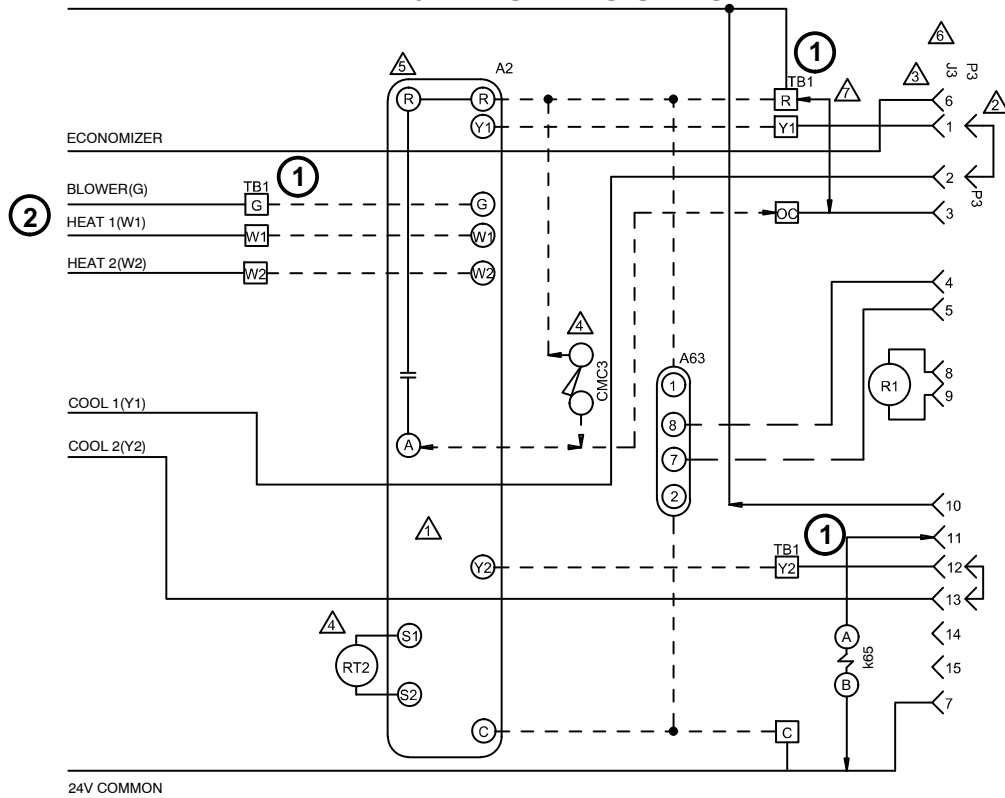

24V COMMON

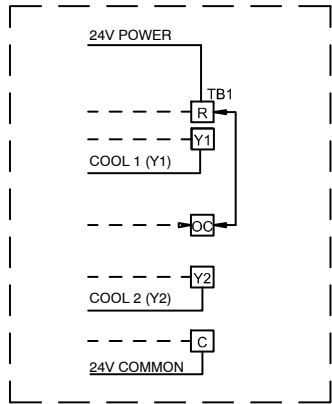

CONNECTION SCHEME FOR KCA, KGA AND KHA 092 THROUGH 150 UNITS WITHOUT ECONOMIZER ONLY

DESCRIPTION	
KEY	COMPONENT
A2	SENSOR, ELECTRONIC THERMOSTAT
A63	SENSOR, CO2
CMC3	CLOCK, TIME
J3	JACK, UNIT ECONOMIZER
K65	RELAY, EXHAUST FAN
P3	PLUG, ECONOMIZER BYPASS
R1	SENSOR, MIXED AIR OR SUPPLY AIR
RT2	SENSOR, REMOTE THERMOSTAT
TB1	TERMINAL STRIP, CLASS II VOLTAGE

- ⚠ THERMOSTAT SUPPLIED BY USER
- ⚠ REMOVE P3 WHEN ECONOMIZERS USED, ONLY ON KCA, KGA AND KHA 180 THROUGH 300 UNITS.
- ⚠ J3 MAXIMUM LOAD 20VA 24VAC CLASS II
- ⚠ TIME CLOCK CONTACTS (OPT) CLOSED OCCUPIED
- ⚠ TOUCHSCREEN THERMOSTAT
- ⚠ J3 AND P3 ARE NOT USED ON KCA, KGA AND KHA 092 THROUGH 150 UNITS WITHOUT ECONOMIZER
- ⚠ REMOVE JUMPER BETWEEN TB1-R AND TB1-OCP WHEN USING A NITE SETBACK THERMOSTAT

— DENOTES OPTIONAL COMPONENTS
- - - CLASS II FIELD WIRING

	WIRING DIAGRAM	12/09
	ACCESSORIES	
ELECTRONIC OR ELECTROMECHANICAL THERMOSTAT		
SECTION C		REV. 2.0
Supersedes	New Form No.	
	537077-01	

© 2009

Lennox Commercial

POWER:

1- Terminal strip TB1 energizes thermostat components with 24VAC.

OPERATION:

2- TB1 receives data from the electronic thermostat A2 (Y1, Y2, W1, W2, G, OCP). The 24VAC signal from TB1 energizes the appropriate components for heat or cool demand.

KHA/KHB SERIES ECONOMIZER

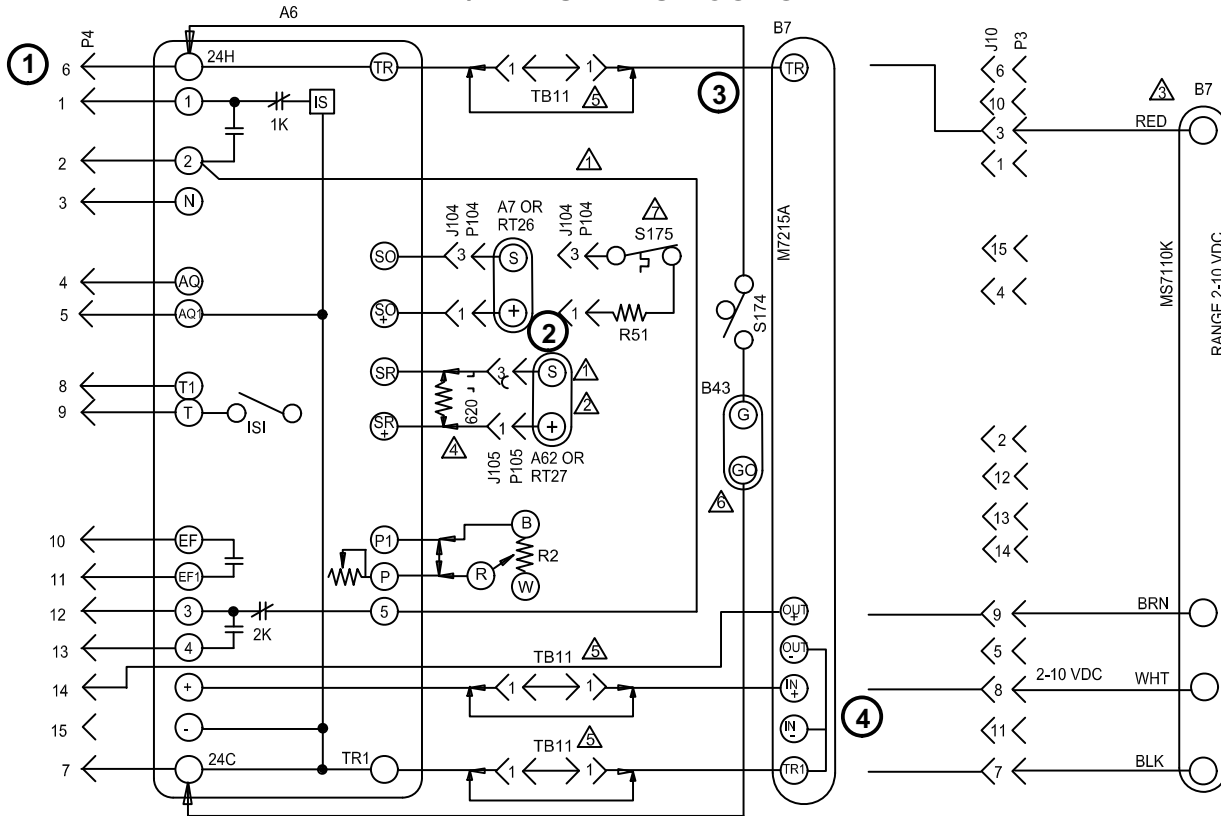

KEY	DESCRIPTION
	COMPONENT
A6	CONTROL-SOLID STATE ENTHALPY
A7	SENSOR-SOLID STATE ENTHALPY
A62	SENSOR-ENTHALPY, INDOOR
B7	MOTOR-DAMPER, ECONOMIZER
B43	MOTOR-EXHAUST DAMPER
J10	JACK-ECONOMIZER
J104	JACK-SENSOR, OUTDOOR ENTHALPY
J105	JACK-SENSOR, RETURN AIR ENTHALPY
P3	PLUG-LESS ECONOMIZER
P4	PLUG-ECONOMIZER
P104	PLUG-SENSOR, OUTDOOR ENTHALPY
P105	PLUG-SENSOR, RETURN AIR ENTHALPY
R2	POT-MINIMUM POSITION
R51	RESISTOR-SENSIBLE 820 OHM
RT26	SENSOR-OUTDOOR AIR TEMP
RT27	SENSOR-INDOOR AIR TEMP
S175	THERMOSTAT-SENSIBLE TEMP 55-70F
S174	SWITCH-EXHAUST DAMPER
TB11	TERMINAL STRIP-CLASS II VOLT

- OPTIONAL OUTDOOR THERMOSTAT TO REPLACE RT26 SENSIBLE SENSOR
- OPTIONAL EXHAUST DAMPER TO HOLD EXHAUST DAMPER CLOSED WHEN OUTSIDE AIR DAMPER IS CLOSED
- TB11 USED ON "C" BOX ONLY WITH MOTOR M7215A
- REPLACE A7 OR RT26 WITH 620 OHM RESISTOR FOR CONTROLS WITH GLOBAL ECON USED ON C BOX UNITS
- A62 ENTHALPY SENSOR OR RT27 USED FOR DIFFERENTIAL SENSING
- RT26 AND RT27, TEMPERATURE SENSORS MAY BE USED INSTEAD OF A7 AND A62 ENTHALPY SENSORS

DESIGNATES OPTIONAL WIRING
 CLASS II FIELD WIRING

	WIRING DIAGRAM	5/09
ACCESSORIES		
ECONOMIZER		
ECONOMIZER SECTION D1		
Supersedes Form No.	New Form No.	
	537080-01	

© 2009

Litho U.S.A.

SEQUENCE OF OPERATION

POWER:

- Terminal strip TB1 energizes the economizer components with 24VAC.

OPERATION:

- Enthalpy sensor A7 and A62 (if differential enthalpy is used) communicates to the economizer control module A6 when to power the damper motor B7.
- Economizer control module A6 supplies B7 with 0 - 10 VDC to control the positioning of economizer.
- The damper actuator provides 2 to 10 VDC position feedback.

EHO-7.5, 15, 22.5, 30, 45 & 60kW Y VOLTAGE KHA/KHB SERIES UNITS

KEY	DESCRIPTION
	COMPONENT
DL2	DELAY-ELECTRIC HEAT
F3	FUSE-ELECTRIC HEAT
F4	FUSE-UNIT
F42	FUSE-ELECTRIC HEAT 2
F43	FUSE-ELECTRIC HEAT 3
F44	FUSE-ELECTRIC HEAT 4
HE1	ELEMENT-ELECT HEAT 1
HE2	ELEMENT-ELECT HEAT 2
HE3	ELEMENT-ELECT HEAT 3
HE4	ELEMENT-ELECT HEAT 4
HE5	ELEMENT-ELECT HEAT 5
HE6	ELEMENT-ELECT HEAT 6
J7	JACK-ELECT HT SUB-BASE KIT
K9-1	RELAY-HEAT
K15-1	CONTACTOR-ELECTRIC HT 1
K16-1	CONTACTOR-ELECTRIC HT 2
P2	PLUG-UNIT, HEAT
P7	PLUG-ELECT HT SUB-BASE KIT
S15	SWITCH-LIMIT, PRIMARY, ELECT HT
S19	THERMOSTAT-ELECTRIC HEAT LIMIT
S20	SWITCH-LIMIT, SECONDARY ELECT HT
S157	SWITCH-LIMIT, SECONDARY ELECT HT 2
S158	SWITCH-LIMIT, SECONDARY ELECT HT 3
S159	SWITCH-LIMIT, SECONDARY ELECT HT 4
S160	SWITCH-LIMIT, SECONDARY ELECT HT 5
S161	SWITCH-LIMIT, SECONDARY ELECT HT 6
TB2	TERMINAL STRIP-UNIT
TB3	TERMINAL STRIP-ELECTRIC HEAT

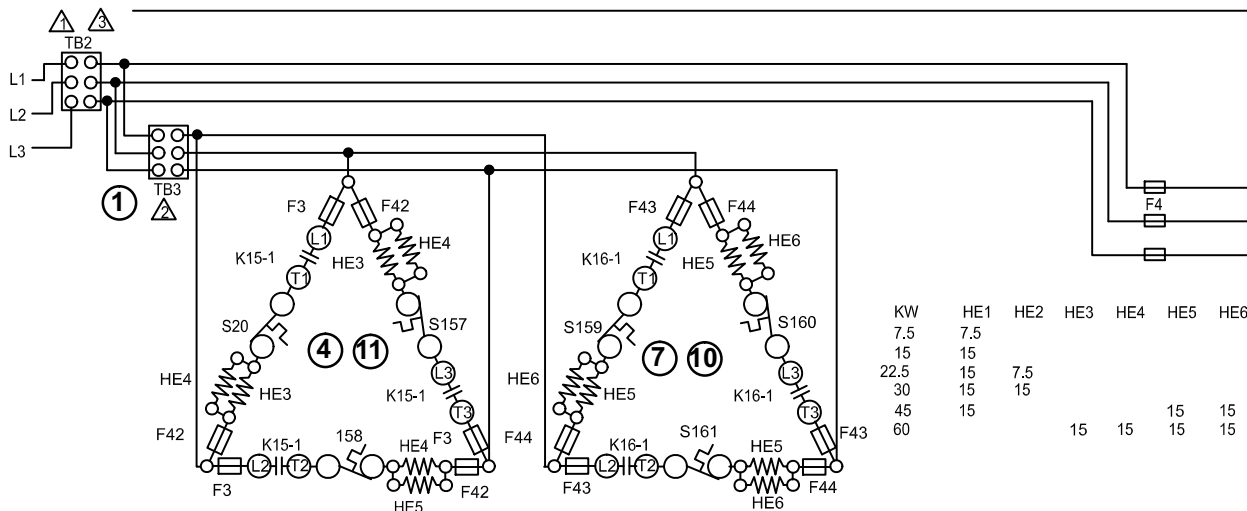
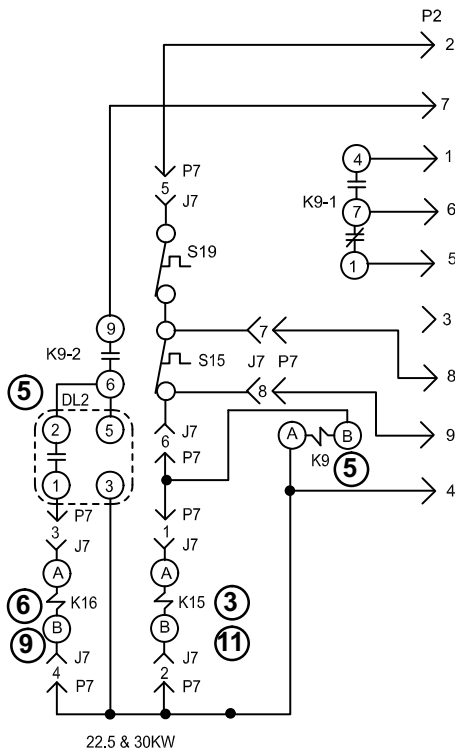

KW	HE1	HE2	HE3	HE4	HE5	HE6
7.5	7.5					
15	15					
22.5	15	7.5				
30	15	15				
45	15					
60			15	15	15	15

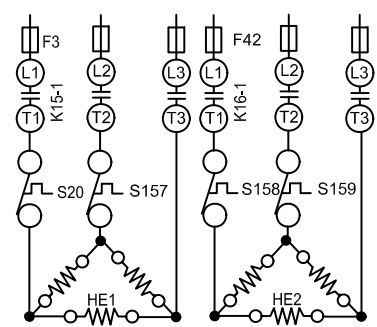

- ⚠ NOT USED ON 7.5, 15, AND 30KW UNITS
- ⚠ TB3 IS USED ON SOME UNITS
- ⚠ TB2, S48 OR CB10 MAY BE USED

WIRING DIAGRAM 8/09

HEATING-ELECTRIC

EHO-7.5, 15, 22.5, 30, 45, 60-Y
FOR USE WITH KCA AND KHA UNITS

B BOX

HEATING SECTION-A5

Supersedes Form No. 534870W	New Form No. 537058-01
---------------------------------------	----------------------------------

EHO-7.5, 15, 22.5, 30, 45 & 60kW G, J VOLTAGE KHA/KHB SERIES UNITS

DESCRIPTION	
KEY	COMPONENT
DL2	DELAY-ELECTRIC HEAT
F3	FUSE-ELECTRIC HEAT
F4	FUSE-UNIT
F42	FUSE-ELECTRIC HEAT 2
HE1	ELEMENT-ELECT HEAT 1
HE2	ELEMENT-ELECT HEAT 2
HE3	ELEMENT-ELECTRIC HEAT 3
HE4	ELEMENT-ELECTRIC HEAT 4
J7	JACK-ELECT HT SUB-BASE KIT
K9-1	RELAY-HEAT
K15-1	CONTACTOR-ELECTRIC HT 1
K16-1	CONTACTOR-ELECTRIC HT 2
P2	PLUG-HEAT
P7	PLUG-ELECT HT SUB-BASE KIT
S15	SWITCH-LIMIT,PRIMARY,ELECT HT
S19	THERMOSTAT-ELECTRIC HEAT LIMIT
S20	SWITCH-LIMIT,SECONDARY ELECT HT
S157	SWITCH-LIMIT,SECONDARY ELECT HT 2
S158	SWITCH-LIMIT,SECONDARY ELECT HT 3
S159	SWITCH-LIMIT,SECONDARY ELECT HT 4
TB2	TERMINAL STRIP-UNIT
TB3	TERMINAL STRIP-ELECTRIC HEAT

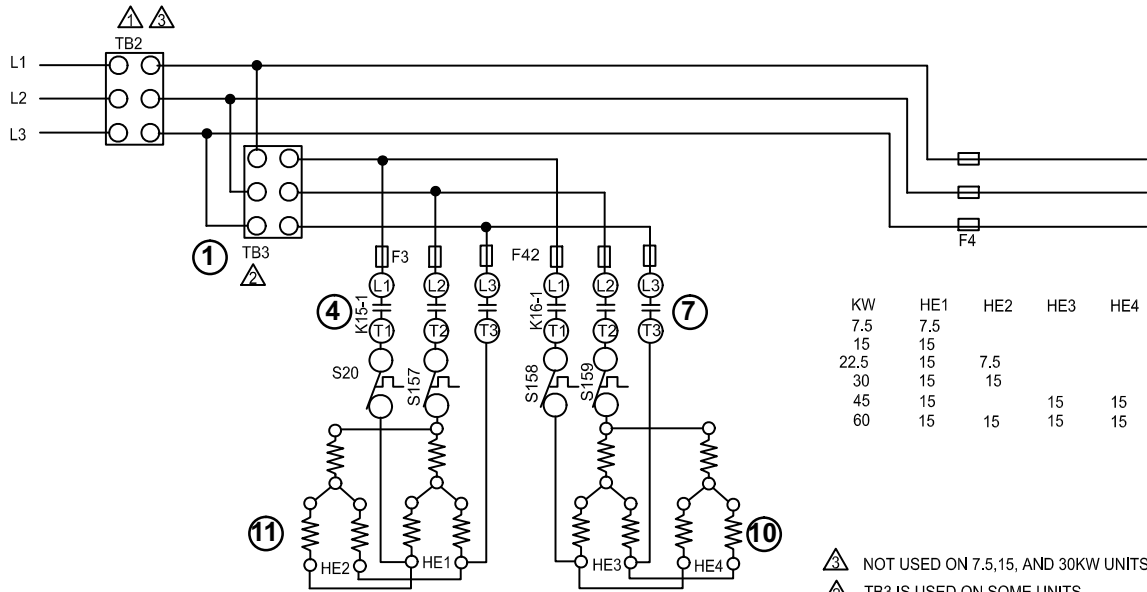
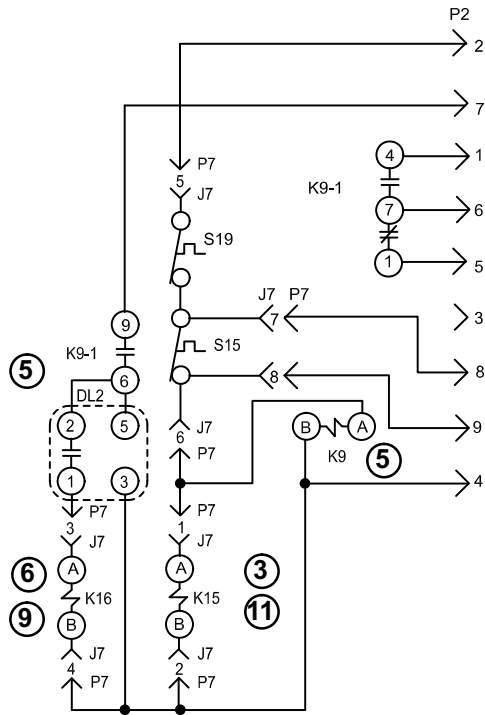

- ⚠ NOT USED ON 7.5,15, AND 30KW UNITS
- ⚠ TB3 IS USED ON SOME UNITS
- ⚠ TB2,S48 OR CB10 MAY BE USED

	WIRING DIAGRAM	8/09
HEATING-ELECTRIC		
EHO-7.5,15,22.5,30,45,60-G,J,M		
FOR USE WITH KCA AND KHA UNITS		
B BOX		
HEATING SECTION-A4		
Supersedes Form No. 534871W	New Form No. 537057-01	
© 2009	Litho U.S.A.	

Sequence of Operation -EHO 7.5, 15, 22.5, 30, 45, 60 kW - Y and G, J, M

NOTE: This sequence of operation is for all Electric Heat kW ratings Y through J voltages. Each step of operation is numbered and can be followed in sequence on the diagrams. Operation for G, J, and M voltages will be the same.

HEATING ELEMENTS:

- 1- Terminal Strip TB3 is energized when the unit disconnect closes. TB3 supplies line voltage to electric heat elements HE1 through HE7. Each element is protected by fuse F3.

SECOND STAGE HEAT:

- 2- Heating demand initiates at W1 in thermostat.
- 3- 24VAC W2 signal is routed through from the thermostat to TB1. After S15 N.C. primary limit and S20 secondary limit is proved, the electric heat contactor K15 is energized.

- 4- N.O. contacts K15-1 close allowing the first bank of elements to be energized.
- 5- Relay K9 is energized. N.O. contacts K9-1 close energizing timer DL2.
- 6- After a 30-second delay, DL2 closes energizing contactor K16.
- 7- N.O. contacts K16-1 close allowing the second bank of elements to be energized.

END OF SECOND STAGE HEAT:

- 8- Heating demand is satisfied. Terminal W1 in the thermostat is de-energized.
- 9- Electric heat contactor K16 is de-energized.
- 10- The second set of electric heat elements are de-energized.
- 11- Electric heat contactor K15 is de-energized.
- 12- The first set of electric heat elements are de-energized.